



Quality Valves Manufacturer, We're WEKE



## Bellows Sealed Valve series 波纹管阀门系列



维柯官方微信, 扫一扫关注我们

温州维柯阀门有限公司  
WENZHOU WEIKE VALVE CO., LTD.

地址: 中国·浙江省温州市永嘉县瓯北镇堡二工业区  
ADD: Baoer Industrial, Oubei Town, 325105, Yongjia Country,  
Wenzhou City, China

电话 TEL: + 86-0577-67388022

传真 FAX: + 86-0577-67388021

网站 Web: [www.weke-valves.com](http://www.weke-valves.com)

邮件 Email: [info@weke-valves.com](mailto:info@weke-valves.com)

温州维柯阀门有限公司  
WENZHOU WEIKE VALVE CO., LTD.

## ABOUT US

### 关于我们

#### 我们是谁

温州维柯阀门有限公司，是一家集研发、生产、销售、服务于一体的专业波纹管阀门生产企业，坐落在“中国泵阀之乡”的温州瓯北。成立于2014年，先后获得出口权，ISO质量认证和欧盟CE安全认证。公司产品80%销往意大利、俄罗斯及越南等地。

#### 我们的产品

A. 德标阀门系列：波纹管截止阀，波纹管直角截止阀，波纹管Y型截止阀，德标闸阀，止回阀，过滤器等等。

B. 美标阀门系列：波纹管截止阀，波纹管闸阀，普通美标闸阀，截止阀，止回阀，球阀等等。

C. 锻钢阀门系列：锻钢波纹管截止阀，锻钢波纹管闸阀，普通锻钢阀门。

我们的宗旨：让管道更安全、更节能、更科技

我们的理念：诚信经营，质量第一，服务创造价值

我们的质量：零泄漏，生产最好的阀门

我们的价值：立足行业，服务社会

我们的远景：跻身阀门行业品牌前列

#### Who are we

Wenzhou Weike Valve Co., Ltd, is a professional manufacturer of bellows valves, which located in Wenzhou Oubei town, the hometown of China's pump and valve.

Established in 2014, it has obtained export license, ISO 9001 and EU CE certification. 80% of the company's products were sold to Italy, Russia and Vietnam etc.

#### Our products

A, DIN standard valve series: bellows globe valve, bellows angle globe valve, bellows Y-type globe valve, F4/F5/F7 gate valve, check valve, Y-Strainer etc.

B, ANSI standard valve series: bellows globe valve, bellows gate valve, ANSI gate valve, globe valve, check valve, ball valve etc.

C, Forged steel valve series: forged bellows globe valve, forged bellows gate valve, forged gate/globe/check valve.

Our aim: To make pipelines more safety, more energy efficient and more technological

Our philosophy: Integrity management, quality first, service creation value

Our quality: Zero leakage, produce the best valve

Our value: Based on the valve industry, serving the society

Our vision: Stand in the forefront of the valve industry



## QUALIFICATION

### 企业资质





**目录**  
**CONTENTS**

01	▲	波纹管阀门特征 BELLOWS VALVE FEATURES
02-03	▲	德标波纹管截止阀 DIN BELLOWS GLOBE VALVE
04-05	▲	德标截止阀 DIN GLOBE VALVE
06-07	▲	德标角式波纹管截止阀 DIN ANGLE BELLOWS GLOBE VALVE
08-09	▲	德标Y型波纹管截止阀 DIN Y-TYPE BELLOWS GLOBE VALVE
10-11	▲	德标闸阀 DIN GATE VALVE
12	▲	德标升降式止回阀 DIN LIFT CHECK VALVE
13	▲	德标Y型过滤器 DIN Y-STRAINER
14-15	▲	美标波纹管截止阀 ANSI BELLOWS GLOBE VALVE
16-17	▲	美标波纹管闸阀 ANSI BELLOWS GATE VALVE
18-19	▲	锻钢波纹管闸阀 FORGED BELLOWS GATE VALVE
20-21	▲	锻钢波纹管截止阀 FORGED BELLOWS GLOBE VALVE
22-23	▲	阀瓣类型的选择 AVAILABLE DISC TYPE
24	▲	特殊设计 SPECIAL DESIGN
25-31	▲	法兰数据 DATA OF FLANGE

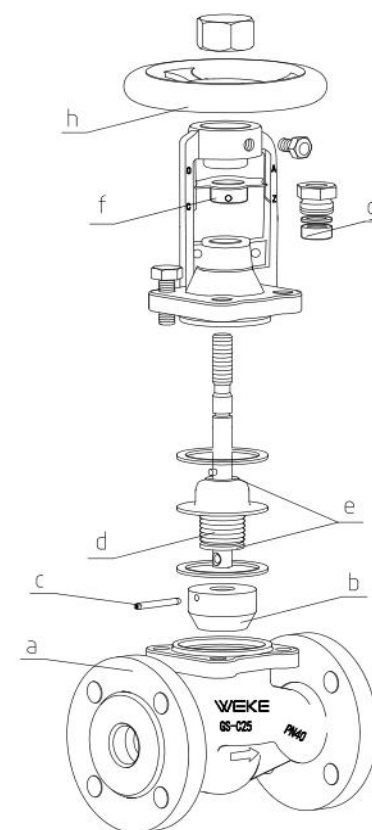
**波纹管阀门特征 BELLOWS VALVE FEATURES**

- a: 阀体采用精密铸造工艺, 先进的工艺了确保阀体无砂眼, 表现光滑, 质量更可靠。  
The valve body adopts investment casting technology. Advanced technology to ensure that the valve body has no sand holes, surface more smooth and quality more reliable.
- b: 锥形密封面能自动清除杂质  
Conical sealing surface will remove impurity automatically.
- c: 活动插销, 易更换阀瓣  
Flexible pin, easy to replace the disc when broken.
- d: 波纹管是波纹管阀门的关键组件, 采用自动滚焊, 焊在阀瓣与阀杆上, 确保阀杆部件100%零泄露。  
Bellow is the key part of bellow sealed valves, which is welded to both the valve bonnet and valve stem, with automatic roll welding. The metal bellow can keep the stem part 100% no leakage.
- e: 波纹管材质为不锈钢, 3层波纹管, 使用寿命达5000次。  
Three layers stainless steel bellows can be use 5000 times.
- f: 波纹管上端焊接上碗盘, 下端焊接在阀杆, 保证介质不会从阀杆泄露。  
The upper end of the bellows is welded to the bowl plate, and the lower end is welded to the valve stem to ensure that the medium does not leak from the valve stem.
- g: 定位片, 能起到限位开关的作用, 更好的保护阀门  
The guide piece limit the valve to open and close, better to protect the valve.
- h: 石墨填料, 第二道密封的作用  
Graphite packing was the second sealing for valves.
- i: 人体工程学设计手轮, 使用寿命更长, 操作轻松便捷且安全可靠。  
Ergonomic hand wheel. It provide longer service life and easier Operation.

**性能优势 PERFORMANCE ADVANGATE**

1. 波纹管是波纹管阀门的关键组件，采用自动滚焊，焊在阀瓣与阀杆上，确保阀杆部件100%零泄露。  
Bellow is the key part of bellow sealed valves, which is welded to both the valve bonnet and valve stem, with automatic roll welding. The metal bellow can keep the stem part 100% no leakage.
2. 双密封设计（波纹管+填料）。波纹管形成第一道金属密封防止泄漏，如果波纹管失效，填料可以提供第二道密封。  
Double seal design (bellows+packing). Bellow form a metal seal to prevent leakage, and packing can provide seal if the bellow failed.
3. 堆焊阀座，即使在恶劣工况下，也能确保可靠的密封。  
Overlay welded seat can keep reliable sealing under severe conditions.
4. 人体工程学设计手轮，使用寿命更长，操作轻松便捷且安全可靠。  
Ergonomic hand wheel. It provide longer service life and easier Operation.

**技术规范 TECHNICAL SPECIFICATION**

设计标准 Design standard: DIN EN 13709:2003  
 结构长度 Face to face dimension: DIN EN 558-1:1995  
 连接法兰 Flanged ends: DIN EN 1092-1:2002  
 对焊连接 Welded ends: DIN EN 12627  
 试验与检验 Test & inspection: DIN EN 12266:2003

**应用 APPLICATION**

热油系统、蒸汽系统、冷热水系统等等  
 Thermal oil system, steam system, hot and cold water system etc.

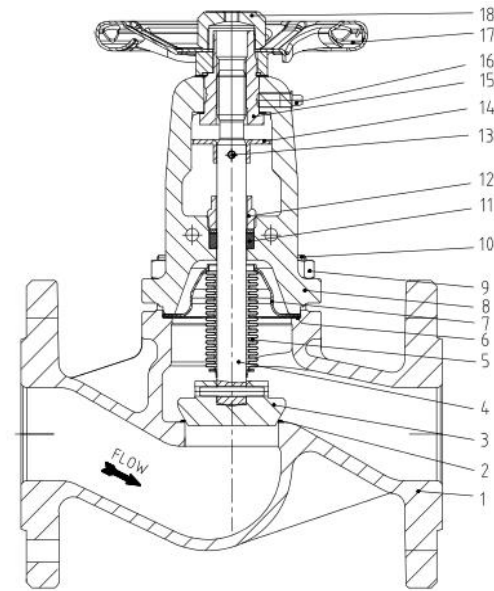
**产品零部件材料 PRODUCT PARTS AND MATERIALS**

序号/No.	零件名称 Parts Name	材质 Materials		
1	阀体 Body	GS-C25/1.0619	CF8/1.4301	CF8M/1.4408
2	阀座 Seat	Overlay 13Cr	SS304	SS316
3	阀瓣密封面 Disc surface	Overlay 13Cr	SS304	SS316
4	阀杆 Stem	X20Cr13	SS304	SS316
5	波纹管 Bellows	SS304/SS316/SS321/SS316Ti	SS304/SS316/SS321/SS316Ti	SS316/SS321/SS316Ti
6	垫片 Gasket	Graphite+SS	Graphite+SS	Graphite+SS
7	波纹管碗盘 Bellows cover	SS304/SS316	SS304/SS316	SS316
8	阀盖 Bonnet	GS-C25/1.0619	CF8/1.4301	CF8M/1.4408
9	螺母 Nut	A194 2H	A194 8	A194 8M
10	螺栓 Bolt	A193 B7	A193 B8	A193 B8M
11	填料 Packing	Graphite	Graphite	Graphite
12	压盖 Gland	C.S	CF8	CF8M
13	插销 Pin	Steel	Steel	Steel
14	定位片 Guide piece	Steel	Steel	Steel
15	阀杆螺母 Stem nut	Ductile iron	Copper alloy	Copper alloy
16	油嘴 Grease Nipple	H2	H2	H2
17	手轮 Hand wheel	Steel	Steel	Steel
18	螺帽 Lock nut	A105	A105	A105

备注 Notes: 以上零件为常规产品材质，如有特殊要求，可根据客户要求变动，如密封面为司太立。  
 Above parts materials are used for conventional product. If there are special requirements, which can be changed according to customer requirements. For example, the sealing can be Stellite.



**主要连接尺寸 MAIN DIMENSIONS(mm)**

Fig.VK811 PN16																
口径 Size DN	15	20	25	32	40	50	65	80	100	125	150	200	250	300	350	400
总长 L RF/BW	130	150	160	180	200	230	290	310	350	400	480	600	730	850	980	1100
外圆 D	95	105	115	140	150	165	185	200	220	250	285	340	405	480	520	580
手轮 W	140	140	160	160	180	200	220	250	300	350	400	450	550	600	700	700
中心高 H	192	192	207	207	245	253	295	328	385	427	480	672	775	852	1005	1140
重量 Weight(kg)	4	4.8	5.8	7.8	9.5	12.5	17	22	36	52	81	135	240	305	510	740
行程 Stroke	8	8	10	10	12	15	17	22	28	34	40	60	75	85	100	110
流量 Kvs(m3/h)	4.2	7.4	12	19	30	47	77	120	188	285	410	725	1140	1660	2230	2950
Fig.VK812 PN25																
口径 Size DN	15	20	25	32	40	50	65	80	100	125	150	200	250	300	350	400
总长 L RF/BW	130	150	160	180	200	230	290	310	350	400	480	600	730	850	980	1100
外圆 D	95	105	115	140	150	165	185	200	220	270	300	360	425	485	555	620
手轮 W	140	140	160	160	180	200	220	250	300	350	400	450	550	600	700	700
中心高 H	192	192	207	207	245	253	295	328	385	427	480	672	775	852	1005	1140
重量 Weight(kg)	4	4.8	5.8	7.8	9.5	12.5	17	22	37	53	82	140	245	315	530	780
行程 Stroke	8	8	10	10	12	15	17	22	28	34	40	60	75	85	100	110
流量 Kvs(m3/h)	4.2	7.4	12	19	30	47	77	120	188	285	410	725	1140	1660	2230	2950
Fig.VK813 PN40																
口径 Size DN	15	20	25	32	40	50	65	80	100	125	150	200	250	300	350	400
总长 L RF/BW	130	150	160	180	200	230	290	310	350	400	480	600	730	850	980	1100
外圆 D	95	105	115	140	150	165	185	200	235	270	300	375	450	515	580	660
手轮 W	140	140	160	160	180	200	220	250	300	350	400	450	550	600	700	700
中心高 H	192	192	207	207	245	253	295	328	385	427	480	672	775	852	1005	1140
重量 Weight(kg)	4	4.8	5.8	7.8	9.5	12.5	17.5	23	38	54	83	142	260	320	560	820
行程 Stroke	8	8	10	10	12	15	17	22	28	34	40	60	75	85	100	110
流量 Kvs(m3/h)	4.2	7.4	12	19	30	47	77	120	188	285	410	725	1140	1660	2230	2950

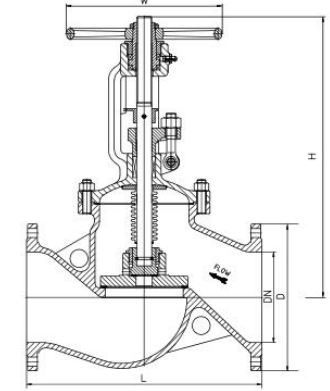
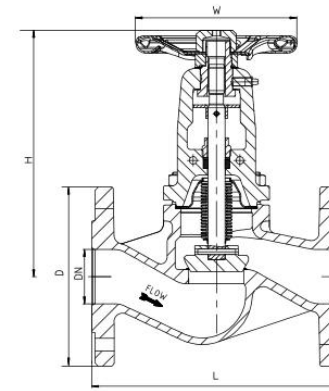

**性能优势 PERFORMANCE ADVANGATE**

1. 阀体采用精密铸造工艺, 先进的工艺了确保阀体无砂眼, 表现光滑, 质量更可靠。  
The valve body adopts investment casting technology. Advanced technology to ensure that the valve body has no sand holes, surface more smooth and quality more reliable.
2. 上密封结构, 当阀门全开时, 上密封结构将起到额外的密封作用, 具有行程定位和抗振功能。  
Back seat structure. In the fully open position, back seat will form a extrasealing, with stroke locate and anti-vibration function.
3. 堆焊阀座, 即使在恶劣工况下, 也能确保可靠的密封。  
Overlay welded seat can keep reliable sealing under severe conditions.
4. 人体工程学设计手轮, 使用寿命更长, 操作轻松便捷且安全可靠。  
Ergonomic hand wheel. It provide longer service life and easier Operation.

**技术规范 TECHNICAL SPECIFICATION**

设计标准 Design standard: DIN EN 13709:2003  
 结构长度 Face to face dimension: DIN EN 558-1:1995  
 连接法兰 Flanged ends: DIN EN 1092-1:2002  
 对焊连接 Welded ends: DIN EN 12627  
 试验与检验 Test & inspection: DIN EN 12266:2003

**应用 APPLICATION**

热油系统、蒸汽系统、冷热水系统等等  
 Thermal oil system, steam system, hot and cold water system etc.

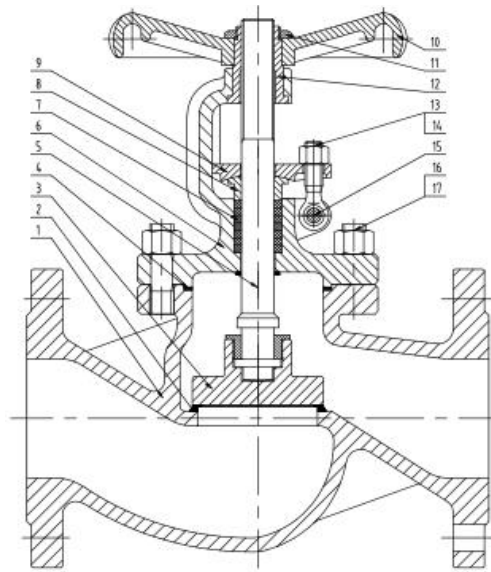
**产品零部件材料 PRODUCT PARTS AND MATERIALS**

序号/No.	零件名称 Parts Name	材质 Materials		
1	阀体 Body	GS-C25/1.0619	CF8/1.4301	CF8M/1.4408
2	阀座 Seat	Overlay 13Cr	SS304	SS316
3	阀瓣密封面 Disc surface	Overlay 13Cr	SS304	SS316
4	垫片 Gasket	Graphite+SS	Graphite+SS	Graphite+SS
5	阀杆 Stem	X20Cr13	SS304	SS316
6	阀盖 Bonnet	GS-C25/1.0619	CF8/1.4301	CF8M/1.4408
7	填料 Packing	Graphite	Graphite	Graphite
8	压盖 Gland	WCB	CF8/1.4301	CF8M/1.4408
9	压盖法兰 Gland flange	WCB	CF8/1.4301	CF8M/1.4408
10	手轮 Hand wheel	Steel	Steel	Steel
11	锁紧螺母 Lock nut	Steel	A194 8	A194 8
12	阀杆螺母 Stem nut	Ductile iron	Copper alloy	Copper alloy
13	吊环螺栓 Eyebolt	A193 B7	A193 B8	A193 B8M
14	螺母 Nut	A194 2H	A194 8	A194 8M
15	插销 Pin	Steel	Steel	Steel
16	阀盖螺栓 Bonnet bolt	A193 B7	A193 B8	A193 B8M
17	阀盖螺母 Bonnet nut	A194 2H	A194 8	A194 8M

备注Notes: 以上零件为常规产品材质, 如有特殊要求, 可根据客户要求变动, 如密封面为司太立。  
 Above parts materials are used for conventional product. If there are special requirements, which can be changed according to customer requirements. For example, the sealing can be Stellite.



**主要连接尺寸 MAIN DIMENSIONS(mm)**

Fig.VK911 PN16																
口径 Size DN	15	20	25	32	40	50	65	80	100	125	150	200	250	300	350	400
总长 L RF/BW	130	150	160	180	200	230	290	310	350	400	480	600	730	850	980	1100
外圆 D	95	105	115	140	150	165	185	200	220	250	285	340	405	480	520	580
手轮 W	140	140	160	160	180	200	220	250	300	350	400	450	550	600	700	700
中心高 H	195	195	215	219	247	256	282	305	385	430	470	650	775	852	1005	1140
重量 Weight(kg)	4.2	5.1	6.2	8.2	9.8	13	17.5	23	37	53	82	140	252	310	540	760
流量 Kvs(m3/h)	4.2	7.4	12	19	30	47	77	120	188	285	410	725	1140	1660	2230	2950
Fig.VK912 PN25																
口径 Size DN	15	20	25	32	40	50	65	80	100	125	150	200	250	300	350	400
总长 L RF/BW	130	150	160	180	200	230	290	310	350	400	480	600	730	850	980	1100
外圆 D	95	105	115	140	150	165	185	200	235	270	300	360	425	485	555	620
手轮 W	140	140	160	160	180	200	220	250	300	350	400	450	550	600	700	700
中心高 H	195	195	215	219	247	256	282	305	385	430	470	650	775	852	1005	1140
重量 Weight(kg)	4.2	5.1	6.2	8.2	9.8	13	18	24	38	55	85	146	265	330	580	790
流量 Kvs(m3/h)	4.2	7.4	12	19	30	47	77	120	188	285	410	725	1140	1660	2230	2950
Fig.VK913 PN40																
口径 Size DN	15	20	25	32	40	50	65	80	100	125	150	200	250	300	350	400
总长 L RF/BW	130	150	160	180	200	230	290	310	350	400	480	600	730	850	980	1100
外圆 D	95	105	115	140	150	165	185	200	235	270	300	375	450	515	580	660
手轮 W	140	140	160	160	180	200	220	250	300	350	400	450	550	600	700	700
中心高 H	195	195	215	219	247	256	282	305	385	430	470	650	775	852	1005	1140
重量 Weight(kg)	4.2	5.1	6.2	8.2	9.8	13	19	25	40	57	88	148	280	350	620	830
流量 Kvs(m3/h)	4.2	7.4	12	19	30	47	77	120	188	285	410	725	1140	1660	2230	2950

**性能优势 PERFORMANCE ADVANGATE**

1. 波纹管是波纹管阀门的关键组件，采用自动滚焊，焊在阀瓣与阀杆上，确保阀杆部件100%零泄露。  
Bellow is the key part of bellow sealed valves, which is welded to both the valve bonnet and valve stem, with automatic roll welding. The metal bellow can keep the stem part 100% no leakage.
2. 双密封设计（波纹管+填料）。波纹管形成第一道金属密封防止泄漏，如果波纹管失效，填料可以提供第二道密封。  
Double seal design(bellows+packing). Bellow form a metal seal to prevent leakage, and packing can provide seal if the bellow failed.
3. 堆焊阀座，即使在恶劣工况下，也能确保可靠的密封。  
Overlay welded seat can keep reliable sealing under severe conditions.
4. 人体工程学设计手轮，使用寿命更长，操作轻松便捷且安全可靠。  
Ergonomic hand wheel. It provide longer service life and easier Operation.

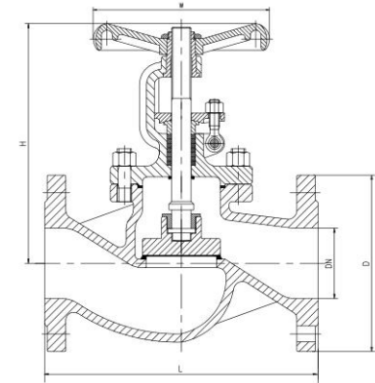
**技术规范 TECHNICAL SPECIFICATION**

设计标准 Design standard: DIN EN 13709:2003  
 结构长度 Face to face dimension: DIN EN 558-1:1995  
 连接法兰 Flanged ends: DIN EN 1092-1:2002  
 对焊连接 Welded ends: DIN EN 12627  
 试验与检验 Test & inspection: DIN EN 12266:2003

**应用 APPLICATION**

热油系统、蒸汽系统、冷热水系统等等  
 Thermal oil system, steam system, hot and cold water system etc.

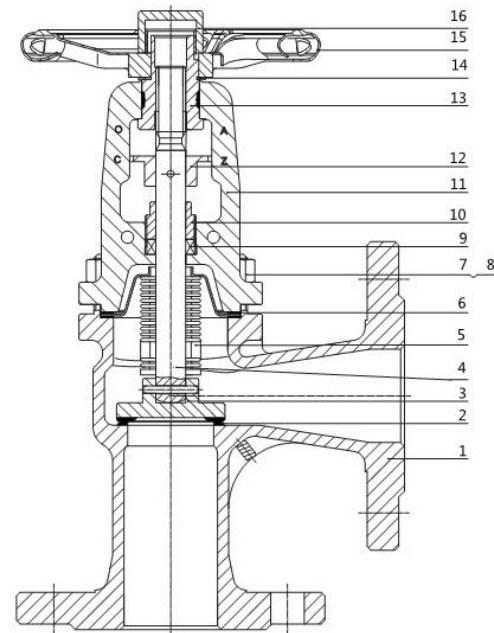
**产品零部件材料 PRODUCT PARTS AND MATERIALS**

序号/No.	零件名称 Parts Name	材质 Materials		
1	阀体 Body	GS-C25/1.0619	CF8/1.4301	CF8M/1.4408
2	阀座 Seat	Overlay 13Cr	SS304	SS316
3	阀瓣密封面 Disc surface	Overlay 13Cr	SS304	SS316
4	阀杆 Stem	X20Cr13	SS304	SS316
5	波纹管 Bellows	SS304/SS316/SS321/SS316Ti	SS304/SS316/SS321/SS316Ti	SS316/SS321/SS316Ti
6	垫片 Gasket	Graphite+SS	Graphite+SS	Graphite+SS
7	螺母 Nut	A194 2H	A194 8	A194 8M
8	螺栓 Bolt	A193 B7	A193 B8	A193 B8M
9	填料 Packing	Graphite	Graphite	Graphite
10	压盖 Gland	Steel	Steel	Steel
11	阀盖 Bonnet	GS-C25/1.0619	CF8/1.4301	CF8M/1.4408
12	定位片 Guide piece	C.S	C.S	C.S
13	阀杆螺母 Stem nut	Ductile iron	Copper alloy	Copper alloy
14	插销 Pin	Steel	Steel	Steel
15	手轮 Hand wheel	Steel	Steel	Steel
16	螺帽 Lock nut	A105	A105	A105

备注Notes: 以上零件为常规产品材质，如有特殊要求，可根据客户要求变动，如密封面为司太立。

Above parts materials are used for conventional product. If there are special requirements, which can be changed according to customer requirements. For example, the sealing can be Stellite.



**主要连接尺寸 MAIN DIMENSIONS(mm)**

Fig.VK711 PN16																
口径 Size DN	15	20	25	32	40	50	65	80	100	125	150	200	250	300	350	400
总长 L RF/BW	90	95	100	105	115	125	145	155	175	200	225	275	325	375	425	475
外圆 D	95	105	115	140	150	165	185	200	220	250	285	340	405	480	520	580
手轮 W	140	140	160	160	180	200	220	250	300	350	400	450	550	600	700	700
中心高 H	200	200	212	212	248	248	287	320	390	412	470	630	740	840	990	1100
重量 Weight(kg)	3.8	4.8	5.7	7.6	9	12	16	22	33	45	70	135	260	305	510	740
行程 Stroke	8	8	10	10	12	15	17	22	28	34	40	60	75	85	100	110
流量 Kvs(m3/h)	4.2	7.4	12	19	30	47	77	120	188	285	410	725	1140	1660	2230	2950
Fig.VK712 PN25																
口径 Size DN	15	20	25	32	40	50	65	80	100	125	150	200	250	300	350	400
总长 L RF/BW	90	95	100	105	115	125	145	155	175	200	225	275	325	375	425	475
外圆 D	95	105	115	140	150	165	185	200	235	270	300	360	425	485	555	620
手轮 W	140	140	160	160	180	200	220	250	300	350	400	450	550	600	700	700
中心高 H	200	200	212	212	248	248	287	320	390	412	470	630	740	840	990	1100
重量 Weight(kg)	3.8	4.8	5.7	7.6	9	12	16	22	34	46	72	138	270	310	520	760
行程 Stroke	8	8	10	10	12	15	17	22	28	34	40	60	75	85	100	110
流量 Kvs(m3/h)	4.2	7.4	12	19	30	47	77	120	188	285	410	725	1140	1660	2230	2950
Fig.VK713 PN40																
口径 Size DN	15	20	25	32	40	50	65	80	100	125	150	200	250	300	350	400
总长 L RF/BW	90	95	100	105	115	125	145	155	175	200	225	275	325	375	425	475
外圆 D	95	105	115	140	150	165	185	200	235	270	300	375	450	515	580	660
手轮 W	140	140	160	160	180	200	220	250	300	350	400	450	550	600	700	700
中心高 H	200	200	212	212	248	248	287	320	390	412	470	630	740	840	990	1100
重量 Weight(kg)	3.8	4.8	5.7	7.6	9	12	16	22	35	48	75	140	275	315	530	770
行程 Stroke	8	8	10	10	12	15	17	22	28	34	40	60	75	85	100	110
流量 Kvs(m3/h)	4.2	7.4	12	19	30	47	77	120	188	285	410	725	1140	1660	2230	2950

**性能优势 PERFORMANCE ADVANGATE**

1. 波纹管是波纹管阀门的关键组件，采用自动滚焊，焊在阀瓣与阀杆上，确保阀杆部件100%零泄露。  
Bellow is the key part of bellow sealed valves, which is welded to both the valve bonnet and valve stem, with automatic roll welding. The metal bellow can keep the stem part 100% no leakage.
2. 双密封设计（波纹管+填料）。波纹管形成第一道金属密封防止泄漏，如果波纹管失效，填料可以提供第二道密封。  
Double seal design (bellows+packing). Bellow form a metal seal to prevent leakage, and packing can provide seal if the bellow failed.
3. 堆焊阀座，即使在恶劣工况下，也能确保可靠的密封。  
Overlay welded seat can keep reliable sealing under severe conditions.
4. 人体工程学设计手轮，使用寿命更长，操作轻松便捷且安全可靠。  
Ergonomic hand wheel. It provide longer service life and easier Operation

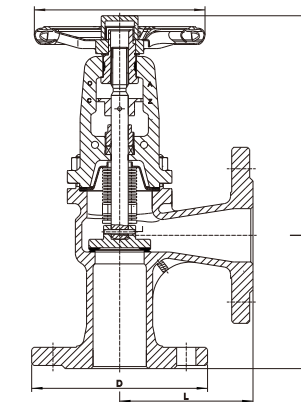
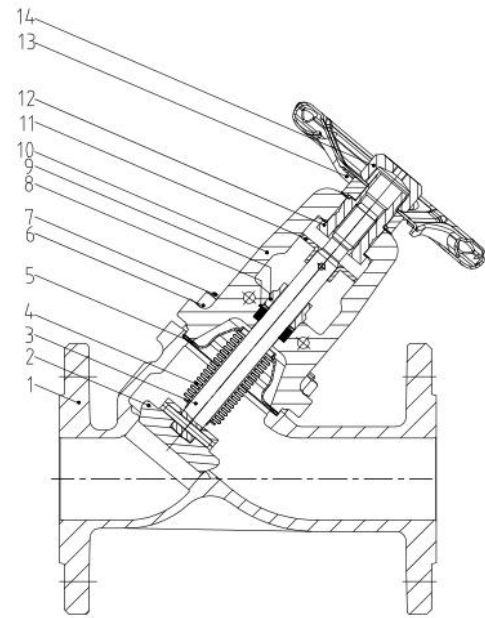
**技术规范 TECHNICAL SPECIFICATION**

设计标准 Design standard: DIN EN 13709:2003  
 结构长度 Face to face dimension: DIN EN 558-1:1995  
 连接法兰 Flanged ends: DIN EN 1092-1:2002  
 对焊连接 Welded ends: DIN EN 12627  
 试验与检验 Test & inspection: DIN EN 12266:2003

**应用 APPLICATION**

热油系统、蒸汽系统、冷热水系统等等  
 Thermal oil system, steam system, hot and cold water system etc.

**产品零部件材料 PRODUCT PARTS AND MATERIALS**

序号/No.	零件名称 Parts Name	材质 Materials		
1	阀体 Body	GS-C25/1.0619	CF8/1.4301	CF8M/1.4408
2	阀瓣 Disc	A105+13CR	SS304	SS316
3	阀杆 Stem	X20Cr13	SS304	SS316
4	波纹管 Bellows	SS304/SS316/SS321/SS316Ti	SS304/SS316/SS321/SS316Ti	SS316/SS321/SS316Ti
5	垫片 Gasket	Graphite+SS	Graphite+SS	Graphite+SS
6	螺母 Nut	A194 2H	A194 8	A194 8M
7	螺栓 Bolt	A193 B7	A193 B8	A193 B8M
8	填料 Packing	Graphite	Graphite	Graphite
9	压盖 Gland	Steel	Steel	Steel
10	阀盖 Bonnet	GS-C25/1.0619	CF8/1.4301	CF8M/1.4408
11	定位片 Guide piece	C.S	C.S	C.S
12	阀杆螺母 Stem nut	Steel	Copper alloy	Copper alloy
13	手轮 Hand wheel	Steel	Steel	Steel
14	螺帽 Lock nut	A105	Steel	Steel

备注Notes: 以上零件为常规产品材质，如有特殊要求，可根据客户要求变动，如密封面为司太立。  
 Above parts materials are used for conventional product. If there are special requirements, which can be changed according to customer requirements. For example, the sealing can be Stellite.



**主要连接尺寸 MAIN DIMENSIONS(mm)**

Fig.VK611 PN16																
口径 Size DN	15	20	25	32	40	50	65	80	100	125	150	200	250	300	350	400
总长 L RF/BW	130	150	160	180	200	230	290	310	350	400	480	600	730	850	980	1100
外圆 D	95	105	115	140	150	165	185	200	220	250	285	340	405	480	520	580
手轮 W	140	140	160	160	180	200	220	250	300	350	400	450	550	600	700	700
中心高 H	192	192	207	207	245	253	295	328	385	427	480	672	775	852	1005	1140
重量 Weight(kg)	4	4.8	5.8	7.8	9.5	12.5	17	22	36	52	81	135	240	305	510	740
行程 Stroke	8	8	10	10	12	15	17	22	28	34	40	60	75	85	100	110
流量 Kvs(m3/h)	4.2	7.4	12	19	30	47	77	120	188	285	410	725	1140	1660	2230	2950
Fig.VK612 PN25																
口径 Size DN	15	20	25	32	40	50	65	80	100	125	150	200	250	300	350	400
总长 L RF/BW	130	150	160	180	200	230	290	310	350	400	480	600	730	850	980	1100
外圆 D	95	105	115	140	150	165	185	200	235	270	300	360	425	485	555	620
手轮 W	140	140	160	160	180	200	220	250	300	350	400	450	550	600	700	700
中心高 H	192	192	207	207	245	253	295	328	385	427	480	672	775	852	1005	1140
重量 Weight(kg)	4	4.8	5.8	7.8	9.5	12.5	17	22	37	53	82	140	245	315	530	760
行程 Stroke	8	8	10	10	12	15	17	22	28	34	40	60	75	85	100	110
流量 Kvs(m3/h)	4.2	7.4	12	19	30	47	77	120	188	285	410	725	1140	1660	2230	2950
Fig.VK613 PN40																
口径 Size DN	15	20	25	32	40	50	65	80	100	125	150	200	250	300	350	400
总长 L RF/BW	130	150	160	180	200	230	290	310	350	400	480	600	730	850	980	1100
外圆 D	95	105	115	140	150	165	185	200	235	270	300	375	450	515	580	660
手轮 W	140	140	160	160	180	200	220	250	300	350	400	450	550	600	700	700
中心高 H	192	192	207	207	245	253	295	328	385	427	480	672	775	852	1005	1140
重量 Weight(kg)	4	4.8	5.8	7.8	9.5	12.5	17.5	23	38	54	83	142	260	320	560	790
行程 Stroke	8	8	10	10	12	15	17	22	28	34	40	60	75	85	100	110
流量 Kvs(m3/h)	4.2	7.4	12	19	30	47	77	120	188	285	410	725	1140	1660	2230	2950

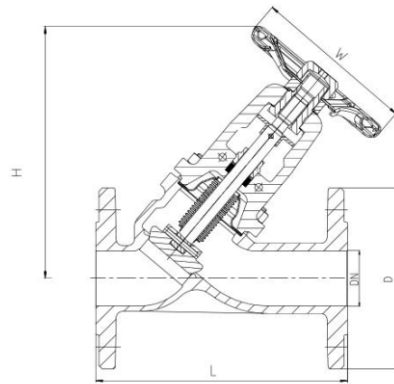

性能优势 PERFORMANCE ADVANGATE

1. 阀体采用精密铸造工艺，先进的工艺了确保阀体无砂眼，表现光滑，质量更可靠。  
The valve body adopts investment casting technology. Advanced technology to ensure that the valve body has no sand holes, surface more smooth and quality more reliable.
2. 堆焊阀座，即使在恶劣工况下，也能确保可靠的密封。  
Overlay welded seat can keep reliable sealing under severe conditions.
3. 人体工程学设计手轮，使用寿命更长，操作轻松便捷且安全可靠。  
Ergonomic hand wheel. It provide longer service life and easier Operation.

设计特征 DESIGN FEATURE

明杆Rising stem 明杆支架式OS&Y  
螺栓阀盖Bolt bonnet 活动闸板Flexible wedge

技术规范 TECHNICAL SPECIFICATION

设计标准Design standard: DIN EN 13709:2003  
结构长度Face to face dimension: DIN EN 558-1:1995  
连接法兰Flanged ends: DIN EN 1092-1:2002  
对焊连接Welded ends: DIN EN 12627  
试验与检验Test & inspection: DIN EN 12266:2003

应用 APPLICATION

热油系统、蒸汽系统、冷热水系统等等  
Thermal oil system, steam system, hot and cold water system etc.

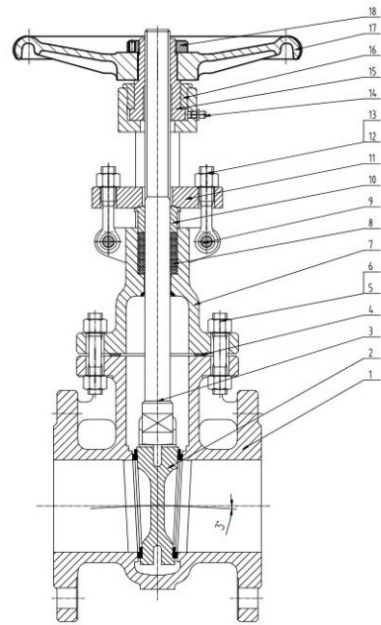

产品零部件材料 PRODUCT PARTS AND MATERIALS

序号/No.	零件名称 Parts Name	材质 Materials		
1	阀体 Body	GS-C25/1.0619+13Cr	CF8/1.4301	CF8M/1.4408
2	阀瓣 Disc	GS-C25+13Cr	SS304	SS316
3	阀杆 Stem	X20Cr13	SS304	SS316
4	垫片 Gasket	Graphite+SS	Graphite+SS	Graphite+SS
5	螺栓 Bolt	A193 B7	A193 B8	A193 B8M
6	螺母 Nut	A194 2H	A194 8	A194 8M
7	阀盖 Bonne	GS-C25/1.0619	CF8/1.4301	CF8M/1.4408
8	填料 Packing	Graphite	Graphite	Graphite
9	插销 Pin	SS410	SS410	SS410
10	压盖 Gland	A105	SS304	SS316
11	压盖法兰 Gland flange	WCB	SS304	SS316
12	螺栓 Bolt	A193 B7	A193 B8	A193 B8M
13	螺母 Nut	A194 2H	A194 8	A194 8M
14	油嘴 Grease Nipple	H2	H2	H2
15	阀杆螺母 Stem nut	Ductile iron	Copper alloy	Copper alloy
16	轴承盖 Bearing cover	A105	SS304	SS316
17	手轮 Hand wheel	Steel	Steel	Steel
18	锁紧螺母 Lock nut	SS410	SS410	SS410

备注Notes: 以上零件为常规产品材质，如有特殊要求，可根据客户要求变动，如密封面为司太立。  
Above parts materials are used for conventional product. If there are special requirements, which can be changed according to customer requirements. For example, the sealing can be Stellite.

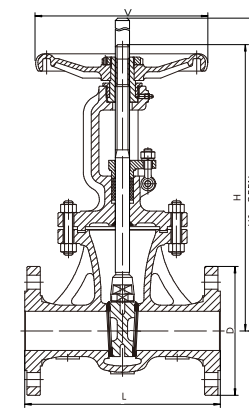
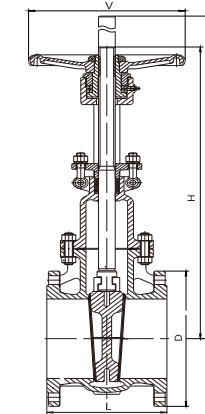

主要连接尺寸MAIN DIMENSIONS(mm)

		Fig.VK511 PN10/16—F4系列																	
口径 Size DN		50	65	80	100	125	150	200	250	300	350	400	450	500	600	700	800	900	1000
总长 L RF/BW		150	170	180	190	200	210	230	250	270	290	310	330	350	390	430	470	510	550
手轮 W		160	180	180	200	220	220	250	300	350	400	450	450	450	450	500	600	-	-
中心高 H		350	420	500	520	610	700	900	1050	1200	1400	1580	1700	1900	2300	2600	3200	-	-
全开高 H1		415	495	580	620	720	840	1100	1300	1540	1750	1980	2150	2450	3000	3500	4100	-	-
重量 kg		17	22	27	38	53	68	108	160	220	275	390	487	560	850	1250	1830	2290	3700
		Fig.VK512 PN16—F5系列																	
口径 Size DN		50	65	80	100	125	150	200	250	300	350	400	450	500	600	700	800	900	1000
总长 L RF/BW		250	270	280	300	325	350	400	450	500	550	600	650	700	800	900	1000	1100	1200
手轮 W		200	200	250	280	300	360	360	400	450	500	500	600	600	680	-	-	-	-
中心高 H		400	420	500	520	610	620	780	1050	1200	1400	1580	1750	1900	2300	2600	3200	4400	4700
全开高 H1		470	495	580	620	720	760	980	1300	1540	1750	1980	2200	2450	3000	3500	4100	5500	5900
重量 kg		22	25	38	45	72	95	165	250	330	470	570	810	1180	1450	1800	2400	3050	3900
		Fig.VK513 PN25—F5系列																	
口径 Size DN		50	65	80	100	125	150	200	250	300	350	400	450	500	600	700	800	900	1000
总长 L RF/BW		250	270	280	300	325	350	400	450	500	550	600	650	700	800	900	1000	1100	1200
手轮 W		200	200	250	280	300	360	360	400	450	500	500	600	600	680	-	-	-	-
中心高 H		400	420	500	520	610	620	780	1050	1200	1400	1580	1750	1900	2300	2600	3200	4400	4700
全开高 H1		470	495	580	620	720	760	980	1300	1540	1750	1980	2200	2450	3000	3500	4100	5500	5900
重量 kg		24	28	40	50	76	108	180	280	350	490	650	920	1250	1560	2030	2550	3870	4500
		Fig.VK514 PN40—F7系列																	
口径 Size DN		50	65	80	100	125	150	200	250	300	350	400	500	600	700	800	900	-	-
总长 L RF/BW		250	290	310	350	400	450	550	650	750	850	950	1150	1350	1550	1750	1950	-	-
手轮 W		200	250	250	300	300	360	400	450	500	600	600	650	750	800	900	1000	-	-
中心高 H		377	390	418	489	541	630	824	915	1085	1190	1310	1560	1875	-	-	-	-	-
全开高 H1		427	455	500	590	665	780	1024	1165	1385	1540	1710	2070	2475	-	-	-	-	-
重量 kg		25	33	45	59	78	116	225	360	515	710	950	1300	2100	3020	-	-	-	-
		Fig.VK515 PN63—F7系列																	
口径 Size DN		50	65	80	100	125	150	200	250	300	350	400	500	600	-	-	-	-	-
总长 L RF/BW		250	290	310	350	400	450	550	650	750	850	950	1150	1350	-	-	-	-	-
手轮 W		200	250	250	300	300	360	400	450	500	600	600	700	800	-	-	-	-	-
中心高 H		450	500	540	670	685	810	970	1155	1330	1500	1680	2100	2400	-	-	-	-	-
全开高 H1		500	570	620	780	810	980	1180	1420	1660	1880	2100	2650	3100	-	-	-	-	-
重量 kg		32	39	53	78	123	176	340	435	560	843	1310	1900	3700	-	-	-	-	-

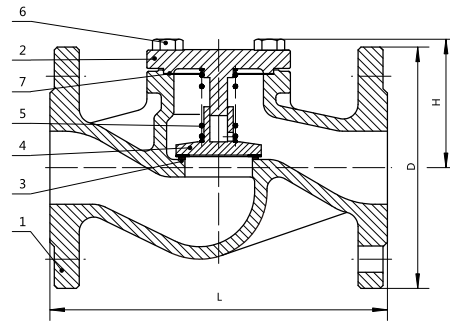

**性能优势 PERFORMANCE ADVANGATE**

- 升降式止回阀为自动密封阀门，本体依靠介质流动而自动开关阀瓣，有效防止介质倒流动。  
Lift check valve is an automatic seal valve, the valve open/close relies on the flow of fluid. Effectively prevent media from flowing backwards.
- 阀瓣带有不锈钢弹簧装置，阀门横竖均可安装。  
The disc with S.S spring can keep the valve work in any direction.
- 产品结构合理，密封可靠，使用寿命长。  
Reasonable product structure, reliable sealing and long service life.

**技术规范 TECHNICAL SPECIFICATION**

设计标准Design standard: DIN EN 13709:2003  
 结构长度Face to face dimension: DIN EN 558-1:1995  
 连接法兰Flanged ends: DIN EN 1092-1:2002  
 对焊连接Welded ends: DIN EN 12627  
 试验与检验Test & inspection: DIN EN 12266:2003

**应用 APPLICATION**

热油系统、蒸汽系统、冷热水系统等等  
 Thermal oil system, steam system, hot and cold water system etc.

**产品零部件材料 PRODUCT PARTS AND MATERIALS**

序号/No.	零件名称 Parts Name	材质 Materials			
1	阀体 Body	GS-C25/1.0619	CF8/1.4301	CF8M/1.4408	
2	阀盖 Bonnet	GS-C25/1.0619	CF8/1.4301	CF8M/1.4408	
3	阀座 Seat	Overlay 13Cr	SS304	SS316	
4	阀瓣密封面 Disc surface	Overlay 13Cr	SS304	SS316	
5	弹簧 Spring	SS304	SS304	SS316	
6	螺栓 Bolt	A193 B7	A193 B8	A193 B8M	
7	垫片 Gasket	Graphite+SS	Graphite+SS	Graphite+SS	

**主要连接尺寸MAIN DIMENSIONS(mm)**

Fig.VK411/412/413 PN16/PN25/PN40																	
口径 Size DN	15	20	25	32	40	50	65	80	100	125	150	200	250	300	350	400	
总长 L RF/BW	130	150	160	180	200	230	290	310	350	400	480	600	730	850	980	1100	
中心高 H	69	70	75	78	85	90	110	125	150	185	285	340	400	445	490	595	
重量 Weight (kg)	PN16	2.8	3.5	4.2	5.5	7.5	9.5	13	17.5	29	40	60	116	210	300	430	670
	PN25	2.8	3.5	4.2	5.5	7.5	9.5	14	19	32	48	73	128	240	320	480	700
	PN40	2.8	3.5	4.2	5.5	7.5	9.5	14	20	33	48	73	135	250	340	500	720
流量 Kvs(m <sup>3</sup> /h)	3.9	6.9	11	17.6	28	43	71	112	174	267	380	670	1060	1514	2060	2690	

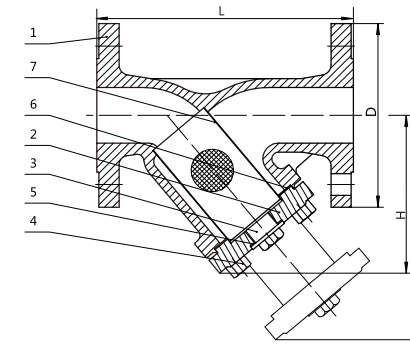
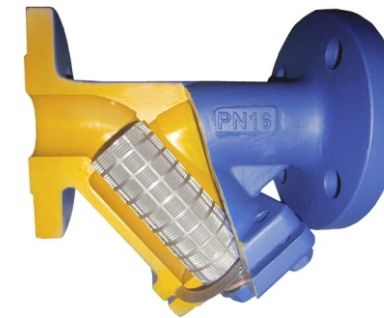
**性能优势 PERFORMANCE ADVANGATE**

- Y-过滤器是用来消除介质中的杂质，能有效保护阀门及设备的正常运转。  
Y-Strainer is used to clean impurities in the medium and can effectively protect the normal operation of valves and equipment.
- 双层不锈钢滤网，杂质过滤更彻底，耐腐蚀性能更好。  
Double stainless steel screen, make a better performance and corrosion-resistance.
- 当需要清洗时，只需将可拆卸的滤网取出，处理干净后重新装入即可，维护极为方便。  
When cleaning is required, just remove the detachable filter, re-load it after cleaning, and it is very convenient to maintain.

**技术规范 TECHNICAL SPECIFICATION**

设计标准Design standard: DIN EN 13709:2003  
 结构长度Face to face dimension: DIN EN 558-1:1995  
 连接法兰Flanged ends: DIN EN 1092-1:2002  
 对焊连接Welded ends: DIN EN 12627  
 试验与检验Test & inspection: DIN EN 12266:2003

**应用 APPLICATION**

热油系统、蒸汽系统、冷热水系统等等  
 Thermal oil system, steam system, hot and cold water system etc.

**产品零部件材料 PRODUCT PARTS AND MATERIALS**

序号/No.	零件名称 Parts Name	材质 Materials			
1	阀体 Body	GS-C25/1.0619	CF8/1.4301	CF8M/1.4408	
2	阀盖 Bonnet	GS-C25/1.0619	CF8/1.4301	CF8M/1.4408	
3	堵头 Plug	A105	SS304	SS316	
4	螺栓 Bolt	A193 B7	A193 B8	A193 B8M	
5	密封片 Sealing piece	SS304	SS304	SS316	
6	垫片 Gasket	Graphite+SS	Graphite+SS	Graphite+SS	
7	滤网 Screen	SS304/SS316	SS304/SS316	SS316	

**主要连接尺寸MAIN DIMENSIONS(mm)**

Fig.VK311/312/313 PN16/PN25/PN40																	
口径 Size DN	15	20	25	32	40	50	65	80	100	125	150	200	250	300	350	400	
总长 L RF/BW	130	150	160	180	200	230	290	310	350	400	480	600	730	850	980	1100	
中心高 H	72	88	105	110	130	140	170	190	240	290	340	425	515	615	725	835	
重量 Weight (kg)	PN16	2.5	3.4	4.6	5.5	7.5	9.5	14	17	26	40	62	109	190	250	400	530
	PN25	2.5	3.4	4.6	5.5	7.5	9.5	15	18	27	44	64	116	205	280	440	580
	PN40	2.5	3.4	4.6	5.5	7.5	9.5	15	18	28	45	65	119	210	290	450	600
流量 Kvs(m <sup>3</sup> /h)	6.3	11	17.5	28	44	69	118	178	270	420	620	1100	1700	2500	3400	4400	

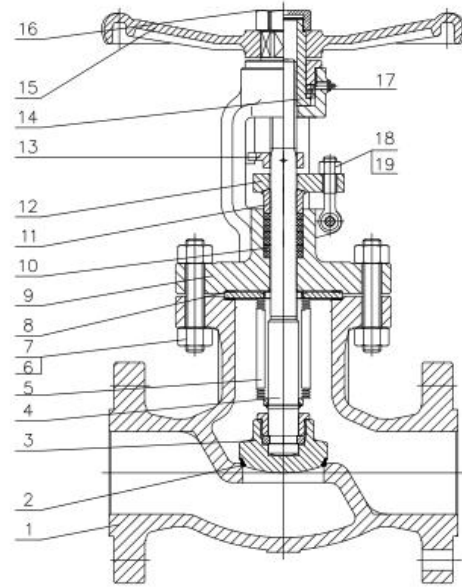
**性能优势 PERFORMANCE ADVANGATE**

1. 波纹管是波纹管阀门的关键组件，采用自动滚焊，焊在阀瓣与阀杆上，确保阀杆部件100%零泄露。  
Bellow is the key part of bellow sealed valves, which is welded to both the valve bonnet and valve stem, with automatic roll welding. The metal bellow can keep the stem part 100% no leakage.
2. 双密封设计（波纹管+填料）。波纹管形成第一道金属密封防止泄漏，如果波纹管失效，填料可以提供第二道密封。  
Double seal design(bellows+packing). Bellow form a metal seal to prevent leakage, and packing can provide seal if the bellow failed.
3. 堆焊阀座，即使在恶劣工况下，也能确保可靠的密封。  
Overlay welded seat can keep reliable sealing under severe conditions.
4. 人体工程学设计手轮，使用寿命更长，操作轻松便捷且安全可靠。  
Ergonomic hand wheel. It provide longer service life and easier Operation.

**技术规范 TECHNICAL SPECIFICATION**

设计标准 Design standard: ASME B16.34  
 结构长度 Face to face dimension: ASME B16.10  
 连接法兰 Flanged ends: ASME B16.5  
 对焊连接 Welded ends: ASME B16.25  
 试验与检验 Test & inspection: API 598

**应用 APPLICATION**

热油系统、蒸汽系统、冷热水系统等等  
 Thermal oil system, steam system, hot and cold water system etc.

**产品零部件材料 PRODUCT PARTS AND MATERIALS**

序号/No.	零件名称 Parts Name	材质 Materials		
1	阀体 Body	WCB	CF8	CF8M
2	阀座 Seat	Overlay 13Cr	SS304	SS316
3	阀瓣密封面 Disc surface	Overlay 13Cr	SS304	SS316
4	阀杆 Stem	X20Cr13	SS304	SS316
5	波纹管 Bellows	SS304/SS316/SS321/SS316Ti	SS304/SS316/SS321/SS316Ti	SS316/SS321/SS316Ti
6	螺栓 Bolt	A193 B7	A193 B8	A193 B8M
7	螺母 Nut	A194 2H	A194 8	A194 8M
8	垫片 Gasket	Graphite+SS	Graphite+SS	Graphite+SS
9	阀盖 Bonnet	WCB	CF8/1.4301	CF8M/1.4408
10	填料 Packing	Graphite	Graphite	Graphite
11	压盖 Gland	A105	CF8	CF8M
12	压盖法兰 Gland flange	WCB	CF8	CF8M
13	定位片 Guide piece	Steel	Steel	Steel
14	阀杆螺母 Stem nut	Ductile iron	Copper alloy	Copper alloy
15	手轮 Hand wheel	Steel	Steel	Steel
16	螺帽 Lock nut	A105	A105	A105
17	油嘴 Grease Nipple	H2	H2	H2
18	螺栓 Bolt	A193 B7	A193 B8	A193 B8M
19	螺母 Nut	A194 2H	A19 48	A194 8M

备注 Notes: 以上零件为常规产品材质，如有特殊要求，可根据客户要求变动，如密封面为司太立。  
 Above parts materials are used for conventional product. If there are special requirements, which can be changed according to customer requirements. For example, the sealing can be Stellite.



**主要连接尺寸 MAIN DIMENSIONS(mm)**

Fig.VK211 150LB											
口径 Size Sin	2"	2-1/2"	3"	4"	5"	6"	8"	10"	12"	14"	16"
口径 Size DN	50	65	80	100	125	150	200	250	300	350	400
总长 L RF/BW	203	216	241	292	356	406	495	622	698	787	914
外圆 D	150	180	190	230	255	280	345	405	485	535	595
手轮 W	220	220	250	300	300	350	400	550	600	600	700
中心高 H	315	330	380	405	455	513	683	736	820	970	1270
重量 Weight(kg)	17	26	43	54	71	95	160	299	373	-	-
Fig.VK212 300LB											
口径 Size Sin	2"	2-1/2"	3"	4"	5"	6"	8"	10"	12"	14"	16"
口径 Size DN	50	65	80	100	125	150	200	250	300	350	400
总长 L RF/BW	267	292	318	356	400	444	559	622	711	838	864
外圆 D	165	190	210	255	280	320	380	445	520	585	650
手轮 W	220	220	250	300	350	400	450	500	600	600	700
中心高 H	328	355	414	433	452	545	725	798	933	1200	1410
重量 Weight(kg)	29	44	59	87	182	165	285	360	580	-	-
Fig.VK213 600LB											
口径 Size Sin	2"	2-1/2"	3"	4"	5"	6"	8"	10"	12"	-	-
口径 Size DN	50	65	80	100	125	150	200	250	300	-	-
总长 L RF/BW	292	330	356	432	508	559	660	787	838	-	-
外圆 D	165	191	210	273	330	356	419	508	559	-	-
手轮 W	250	280	280	350	400	500	550	600	700	-	-
中心高 H	360	410	465	545	625	785	930	-	-	-	-
重量 Weight(kg)	35	42	66	118	245	470	-	-	-	-	-

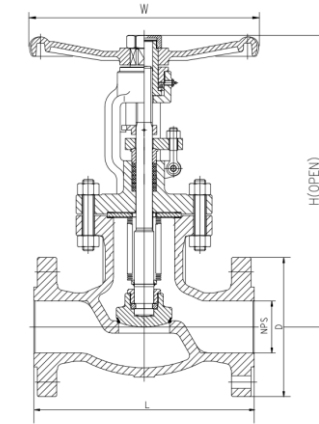
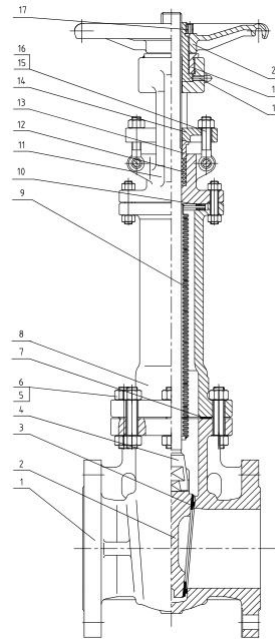

**性能优势 PERFORMANCE ADVANGATE**

1. 波纹管是波纹管阀门的关键组件，采用自动滚焊，焊在阀瓣与阀杆上，确保阀杆部件100%零泄露。  
Bellow is the key part of bellow sealed valves, which is welded to both the valve bonnet and valve stem, with automatic roll welding. The metal bellow can keep the stem part 100% no leakage.
2. 双密封设计（波纹管+填料）。波纹管形成第一道金属密封防止泄漏，如果波纹管失效，填料可以提供第二道密封。  
Double seal design (bellows+packing). Bellow form a metal seal to prevent leakage, and packing can provide seal if the bellow failed.
3. 堆焊阀座，即使在恶劣工况下，也能确保可靠的密封。  
Overlay welded seat can keep reliable sealing under severe conditions.
4. 人体工程学设计手轮，使用寿命更长，操作轻松便捷且安全可靠。  
Ergonomic hand wheel. It provide longer service life and easier Operation.

**技术规范 TECHNICAL SPECIFICATION**

设计标准 Design standard: API 600  
 结构长度 Face to face dimension: ASME B16.10  
 连接法兰 Flanged ends: ASME B16.5  
 对焊连接 Welded ends: ASME B16.25  
 试验与检验 Test & inspection: API 598

**应用 APPLICATION**

热油系统、蒸汽系统、冷热水系统等等  
 Thermal oil system, steam system, hot and cold water system etc.

**产品零部件材料 PRODUCT PARTS AND MATERIALS**

序号/No.	零件名称 Parts Name	材质 Materials		
1	阀体 Body	WCB	CF8	CF8M
2	阀瓣 Disc	WCB+13Cr	CF8+STL.6	CF8M+STL.6
3	阀座密封面 Disc surface	Overlay 13Cr	SS304	SS316
4	阀杆 Stem	X20Cr13	SS304	SS316
5	螺栓 Bolt	A193 B7	A193 B8	A193 B8M
6	螺母 Nut	A194 2H	A194 8	A194 8M
7	垫片 Gasket	Graphite+SS	Graphite+SS	Graphite+SS
8	加长阀盖 Extended bonnet	WCB	CF8	CF8M
9	波纹管 Bellows	SS304/SS316/SS321/SS316Ti	SS304/SS316/SS321/SS316Ti	SS316/SS321/SS316Ti
10	垫片 Gasket	Graphite+SS	Graphite+SS	Graphite+SS
11	阀盖 Bonnet	WCB	CF8	CF8M
1t2	填料 Packing	Graphite	Graphite	Graphite
13	压盖 Gland	A105	CF8	CF8M
14	压盖法兰 Gland flange	WCB	CF8	CF8M
15	螺栓 Bolt	A193 B7	A193 B8	A193 B8M
16	螺母 Nut	A194 2H	A194 8	A194 8M
17	锁紧螺母 Lock nut	A105	A105	A105
18	油嘴 Grease Nipple	H2	H2	H2
19	阀杆螺母 Stem nut	Ductile iron	Copper alloy	Copper alloy
20	手轮 Hand wheel	Steel	Steel	Steel

备注 Notes: 以上零件为常规产品材质，如有特殊要求，可根据客户要求变动，如密封面为司太立。  
 Above parts materials are used for conventional product. If there are special requirements, which can be changed according to customer requirements. For example, the sealing can be Stellite.



**主要连接尺寸 MAIN DIMENSIONS(mm)**

Fig.VK111 150LB														
口径 NPS in	2"	2-1/2"	3"	4"	5"	6"	8"	10"	12"	14"	16"	18"	20"	24"
口径 Size DN	50	65	80	100	125	150	200	250	300	350	400	450	500	600
总长 L RF	178	191	203	229	254	267	292	330	356	381	406	432	457	508
总长 L RTJ	191	203	216	241	267	279	305	434	368	394	419	445	470	521
总长 L BW	216	241	283	305	381	403	419	457	502	572	610	660	711	813
外圆 D	152	178	190	229	254	279	343	406	483	533	597	635	699	813
手轮 W	200	200	250	280	280	300	360	400	450	500	500	600	700	800
中心高 H	440	520	570	690	810	920	1200	1450	1650	1920	2150	2450	2700	3200
Fig.VK112 300LB														
口径 NPS in	2"	2-1/2"	3"	4"	5"	6"	8"	10"	12"	14"	16"	18"	20"	24"
口径 Size DN	50	65	80	100	125	150	200	250	300	350	400	450	500	600
总长 L RF	216	241	283	305	381	403	419	457	502	762	838	914	991	1143
总长 L RTJ	232	257	298	321	397	419	435	473	518	778	854	930	1010	1165
总长 L BW	216	241	283	305	381	403	419	457	502	762	838	914	991	1143
外圆 D	165	191	210	254	279	318	381	445	521	584	648	711	775	914
手轮 W	200	200	250	280	300	350	400	450	500	600	600	650	700	800
中心高 H	450	560	590	730	850	960	1250	1500	1720	2100	2250	2620	2900	3380
Fig.VK113 600LB														
口径 NPS in	2"	2-1/2"	3"	4"	5"	6"	8"	10"	12"	14"	16"	18"	20"	24"
口径 Size DN	50	65	80	100	125	150	200	250	300	350	400	450	500	600
总长 LRF	292	330	356	432	508	559	660	787	838	889	991	1092	1194	1397
总长 L RTJ	295	333	359	435	511	562	664	791	841	892	994	1095	1200	1407
总长 L BW	292	330	356	432	508	559	660	787	838	889	991	1092	1194	1397
外圆 D	165	191	210	273	330	356	419	508	559	603	686	743	813	940
手轮 W	200	250	280	300	350	450	500	650	700	800	900	900	-	-
中心高 H	465	585	600	750	870	980	1270	1525	1750	2140	2270	2650	2930	3390

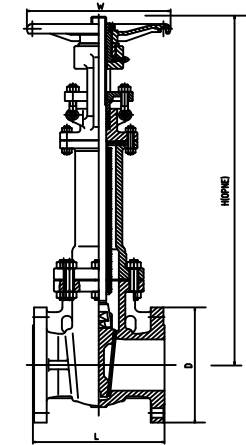
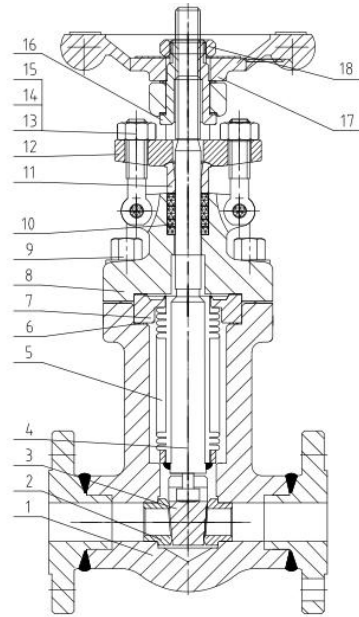

### 性能优势 PERFORMANCE ADVANGATE

1. 波纹管是波纹管阀门的关键组件，采用自动滚焊，焊在阀瓣与阀杆上，确保阀杆部件100%零泄露。  
Bellow is the key part of bellows sealed valves, which is welded to both the valve bonnet and valve stem, with automatic roll welding. The metal bellow can keep the stem part 100% no leakage.
2. 双密封设计（波纹管+填料）。波纹管形成第一道金属密封防止泄漏，如果波纹管失效，填料可以提供第二道密封。  
Double seal design(bellows+packing). Bellow form a metal seal to prevent leakage, and packing can provide seal if the bellow failed.

### 设计特征 DESIGN FEATURE

- 螺栓阀盖 Bolt bonnet(BB)
- 焊接阀盖 Welded bonnet (WB)
- 明杆支架型 Outside screw and yoke(OS&Y)

### 技术规范 TECHNICAL SPECIFICATION

- 设计标准 Design standard: API 602; MSS-SP-117  
 连接端 Connection ends:  
 (1) 承插焊 Socket welded end: ANSI B16.11  
 (2) 螺纹 Screw end: ANSI B1.20.1  
 (3) 对焊 Butt-welded end: ANSI B16.25  
 (4) 法兰 Flange end: ANSI B16.5  
 结构长度 Face to face dimension: ASME B16.10  
 连接法兰 Flanged ends: ASME B16.5  
 对焊连接 Welded ends: ASME B16.25  
 试验与检验 Test & inspection: API 598

### 应用 APPLICATION

热油系统、蒸汽系统、冷热水系统等等  
 Thermal oil system, steam system, hot and cold water system etc.

### 产品零部件材料 PRODUCT PARTS AND MATERIALS

序号/No.	零件名称 Parts Name	材质 Materials		
1	阀体 Body	A105	F304	F316
2	阀座 Seat	13Cr	F304	F316
3	阀瓣 Disc	13Cr	F304	F316
4	阀杆 Stem	X20Cr13	SS304	SS316
5	波纹管 Bellows	SS304/SS316/SS321/SS316Ti	SS304/SS316/SS321/SS316Ti	SS316/SS321/SS316Ti
6	垫片 Gasket	Graphite+SS	Graphite+SS	Graphite+SS
7	波纹管连接片 Bellow cover	SS304	SS304	SS316
8	阀盖 Bonnet	A105	F304	F316
9	螺栓 Bolt	A193 B7	A193 B8	A193 B8M
10	填料 Packing	Graphite	Graphite	Graphite
11	压盖 Gland	A105	F304	F316
12	压盖法兰 Gland flange	WCB	F304	F316
13	螺栓 Bolt	A193 B7	A193 B8	A193 B8M
14	螺母 Nut	A194 2H	A194 8	A194 8M
15	插销 Pin	SS410	SS410	SS410
16	阀杆螺母 Stem nut	Ductile iron	Copper alloy	Copper alloy
17	手轮 Hand wheel	Steel	Steel	Steel
18	锁紧螺母 Lock nut	A105	A105	A105

备注Notes: 以上零件为常规产品材质，如有特殊要求，可根据客户要求变动，如密封面为司太立。

Above parts materials are used for conventional product. If there are special requirements, which can be changed according to customer requirements. For example, the sealing can be Stellite.

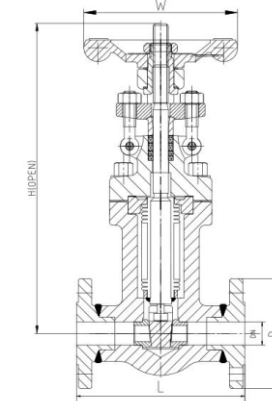

### 主要连接尺寸 MAIN DIMENSIONS(mm)

Fig.VK114 800LB									
缩颈	Reduce bore	-	1/2"	3/4"	1"	1-1/4"	1-1/2"	2"	-
通径	Full bore	1/4"	3/8"	1/2"	3/4"	1"	1-1/4"	1-1/2"	2"
总长 FTF	L SW/BW/NPT	79	79	92	111	120	120	140	178
手轮	Handwheel(W)	100	100	100	125	160	160	180	200
中心高(开)	H(OPEN)	237	237	239	270	298	340	395	470
流道口大小 d	Port diameter(d)	7.5	10.5	13.5	18	24	29	36.5	45
重量	Weight(kg)	3.0	3.0	3.3	5.9	8.7	10.2	16.2	18.8
Fig.VK115 1500LB									
缩颈	Reduce bore	-	1/2"	3/4"	1"	1-1/4"	1-1/2"	2"	-
通径	Full bore	1/4"	3/8"	1/2"	3/4"	1"	1-1/4"	1-1/2"	2"
总长 FTF	L SW/BW/NPT	79	111	111	120	120	140	178	180
手轮	Handwheel(W)	100	125	125	160	160	180	200	220
中心高(开)	H(OPEN)	294	330	380	380	400	450	520	650
流道口大小 d	Port diameter(d)	7.5	10.5	13.5	18	24	29	36.5	45
重量	Weight(kg)	3.3	3.5	5.0	7.5	10	16	25	29
Fig.VK111/112/113 150LB/300LB/600LB									
缩颈	Reduce bore	1/4"	3/8"	1/2"	3/4"	1"	1-1/4"	1-1/2"	2"
总长 FTF L	150LB RF	-	-	108	117	127	140	165	178
	300LB RF	-	-	140	152	165	178	190	216
	600LB RF	-	-	165	190	216	229	241	292
手轮	Handwheel(W)	-	-	100	100	125	160	160	180
中心高(开) H(OPEN)	150LB	-	-	340	340	360	380	450	540
	300LB	-	-	350	350	375	400	470	570
	600LB	-	-	360	360	390	430	500	600
流道口大小 d	Port diameter(d)	-	-	9.0	13	17.5	23	30	35
重量 Weight(kg)	150LB RF/BW	-	-	4.2/3.5	4.8/4.1	7.7/6.4	12.5/11	14.5/12.5	21/18
	300LB RF/BW	-	-	4.5/3.7	5.2/4.2	8.2/7.1	14.5/12	16/13	22/19
	600LB RF/BW	-	-	6.0/5.0	8.0/6.5	13/10	18/15	25/19	40/35

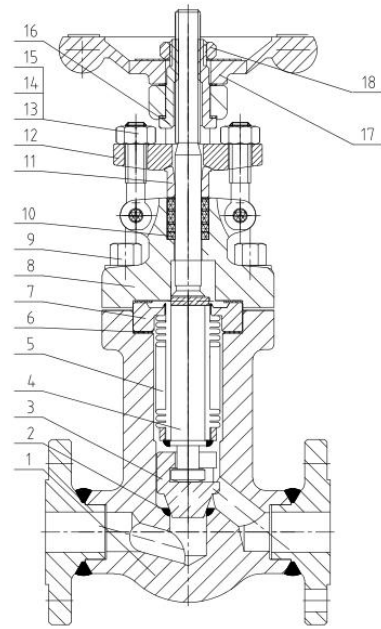

**性能优势 PERFORMANCE ADVANGATE**

1. 波纹管是波纹管阀门的关键组件，采用自动滚焊，焊在阀瓣与阀杆上，确保阀杆部件100%零泄露。  
Bellow is the key part of bellow sealed valves, which is welded to both the valve bonnet and valve stem, with automatic roll welding. The metal bellow can keep the stem part 100% no leakage.
2. 双密封设计（波纹管+填料）。波纹管形成第一道金属密封防止泄漏，如果波纹管失效，填料可以提供第二道密封。  
Double seal design(bellows+packing). Bellow form a metal seal to prevent leakage, and packing can provide seal if the bellow failed.

**设计特征 DESIGN FEATURE**

- 螺栓阀盖 Bolt bonnet(BB)
- 焊接阀盖 Welded bonnet (WB)
- 明杆支架型 Outside screw and yoke(OS&Y)

**技术规范 TECHNICAL SPECIFICATION**

- 设计标准 Design standard: API 602; MSS-SP-117
- 连接端 Connection ends:
  - (1) 承插焊 Socket welded end: ANSI B16.11
  - (2) 螺纹 Screw end: ANSI B1.20.1
  - (3) 对焊 Butt-welded end: ANSI B16.25
  - (4) 法兰 Flange end: ANSI B16.5
- 结构长度 Face to face dimension: ASME B16.10
- 连接法兰 Flanged ends: ASME B16.5
- 对焊连接 Welded ends: ASME B16.25
- 试验与检验 Test & inspection: API 598

**应用 APPLICATION**

热油系统、蒸汽系统、冷热水系统等等  
Thermal oil system, steam system, hot and cold water system etc.

**产品零部件材料 PRODUCT PARTS AND MATERIALS**

序号/No.	零件名称 Parts Name	材质 Materials		
1	阀体 Body	A105	F304	F316
2	阀座 Seat	13Cr	F304	F316
3	阀瓣 Disc	13Cr	F304	F316
4	阀杆 Stem	X20Cr13	SS304	SS316
5	波纹管 Bellows	SS304/SS316/SS321/SS316Ti	SS304/SS316/SS321/SS316Ti	SS316/SS321/SS316Ti
6	垫片 Gasket	Graphite+SS	Graphite+SS	Graphite+SS
7	波纹管连接片 Bellow cover	SS304	SS304	SS316
8	阀盖 Bonnet	A105	F304	F316
9	螺栓 Bolt	A193 B7	A193 B8	A193 B8M
10	填料 Packing	Graphite	Graphite	Graphite
11	压盖 Gland	A105	F304	F316
12	压盖法兰 Gland flange	WCB	F304	F316
13	螺栓 Bolt	A193 B7	A193 B8	A193 B8M
14	螺母 Nut	A194 2H	A194 8	A194 8M
15	插销 Pin	SS410	SS410	SS410
16	阀杆螺母 Stem nut	Ductile iron	Copper alloy	Copper alloy
17	手轮 Hand wheel	Steel	Steel	Steel
18	锁紧螺母 Lock nut	A105	A105	A105

备注Notes: 以上零件为常规产品材质，如有特殊要求，可根据客户要求变动，如密封面为司太立。  
Above parts materials are used for conventional product. If there are special requirements, which can be changed according to customer requirements. For example, the sealing can be Stellite.



**主要连接尺寸 MAIN DIMENSIONS(mm)**

Fig.VK214 800LB									
缩颈	Reduce bore	-	1/2"	3/4"	1"	1-1/4"	1-1/2"	2"	-
通径	Full bore	1/4"	3/8"	1/2"	3/4"	1"	1-1/4"	1-1/2"	2"
总长FTF	L SW/BW/NPT	79	79	92	111	120	152	172	200
手轮	Handwheel(W)	100	100	100	125	160	160	180	200
中心高(开)	H(OPEN)	237	237	239	270	298	340	395	470
流道口大小d	Port diameter(d)	7.5	10.5	13.5	18	24	29	36.5	45
重量	Weight(kg)	3.0	3.0	3.3	5.9	8.7	10.2	16.2	18.8
Fig.VK215 1500LB									
缩颈	Reduce bore	-	1/2"	3/4"	1"	1-1/4"	1-1/2"	2"	-
通径	Full bore	1/4"	3/8"	1/2"	3/4"	1"	1-1/4"	1-1/2"	2"
总长FTF	L SW/BW/NPT	92	111	111	120	152	172	200	220
手轮	Handwheel(W)	100	125	125	160	160	180	200	220
中心高(开)	H(OPEN)	294	330	380	380	400	450	520	650
流道口大小d	Port diameter(d)	7.5	10.5	13.5	18	24	29	36.5	45
重量	Weight(kg)	3.3	3.5	5.0	7.5	10	16	25	29
Fig.VK211/212/213 150LB/300LB/600LB									
缩颈	Reduce bore	1/4"	3/8"	1/2"	3/4"	1"	1-1/4"	1-1/2"	2"
总长FTF L	150LB RF	-	-	108	117	127	140	165	203
	300LB RF	-	-	152	178	203	216	229	267
	600LB RF	-	-	165	190	216	229	241	292
手轮	Handwheel(W)	-	-	100	100	125	160	160	180
中心高(开) H(OPEN)	150LB	-	-	340	340	360	380	450	540
	300LB	-	-	350	350	375	400	470	570
	600LB	-	-	360	360	390	430	500	600
流道口大小d	Port diameter(d)	-	-	9.0	13	17.5	23	30	35
重量 Weight(kg)	150LBRF/BW	-	-	4.2/3.5	4.8/4.1	7.7/6.4	12.5/11	14.5/12.5	21/18
	300LBRF/BW	-	-	4.5/3.7	5.2/4.2	8.2/7.1	14.5/12	16/13	22/19
	600LBRF/BW	-	-	6.0/5.0	8.0/6.5	13/10	18/15	25/19	40/35

更多可供选择的阀瓣类型，且易于更换。 More disc types are available, and easy to replace.

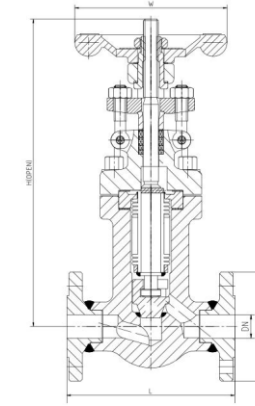
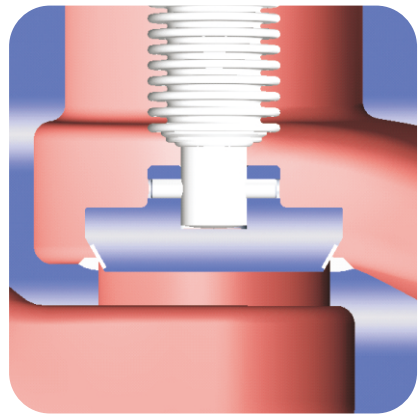
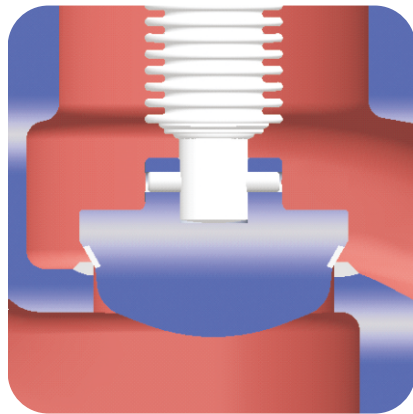

阀瓣型号/Disc type: D1  
锥形密封面能自动清除杂质  
Conical sealing surface will remove impurity automatically



阀瓣型号/Disc type: D2  
抛物线型阀瓣设计能更好的提高水锤的耐受力  
Conical sealing surface will remove impurity automatically

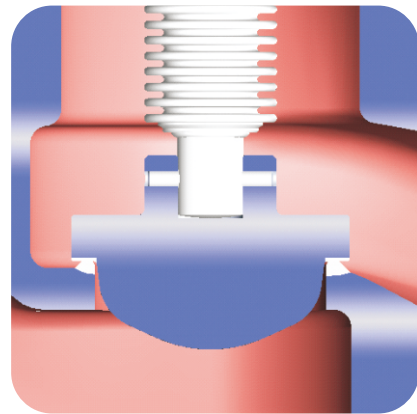

阀瓣型号/Disc type: D3  
平滑的密封表面和流线型的阀瓣，具有更好的提高水锤的耐受力并可以安装在任何公位置  
Flat sealing surface and streamline disc, with better tolerance to water hammer, and can be installed in any position.

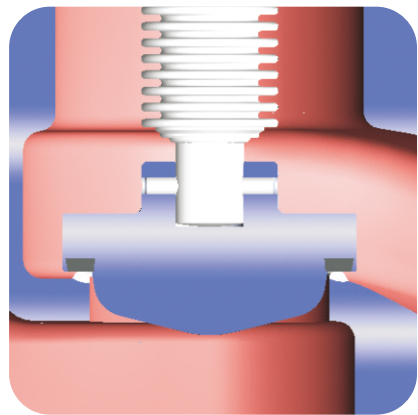

阀瓣型号/Disc type: D4  
当开启或关闭时，软密封面可以防止火花，流线型的阀瓣可以调节流量  
Soft sealing surface can prevent sparks. When opening and closing. Streamline disc can regulate flow rate

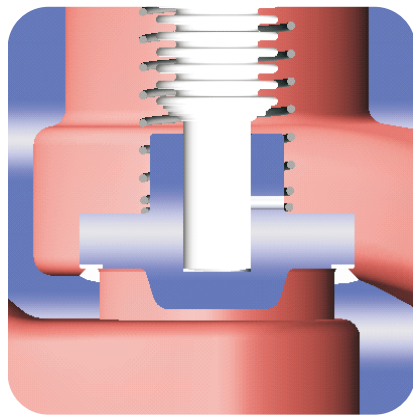

阀瓣型号/Disc type: D5  
截止止回阀的阀瓣和弹簧，可以安装在任何位置  
SDNR (Globe-check) disc with spring, it can be installed in any position

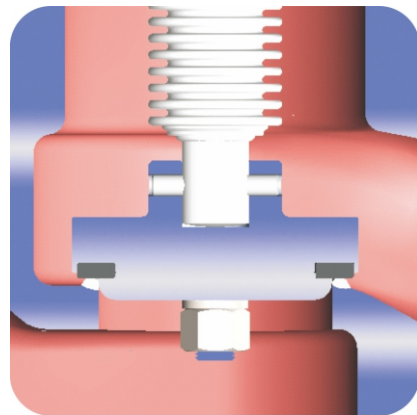

阀瓣型号/Disc type: D6  
软密封表面能防止火花，且容易更换  
Soft sealing surface can prevent sparks, and easy for replacement

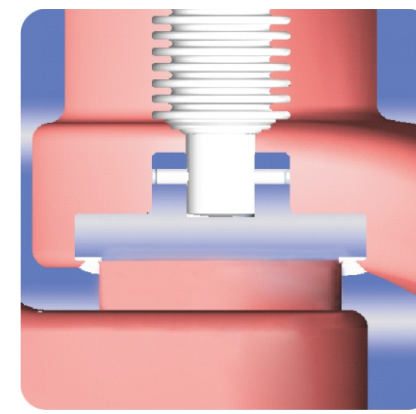

阀瓣型号/Disc type: D7  
平面阀瓣，开关反应迅速  
Flat disc, fast action

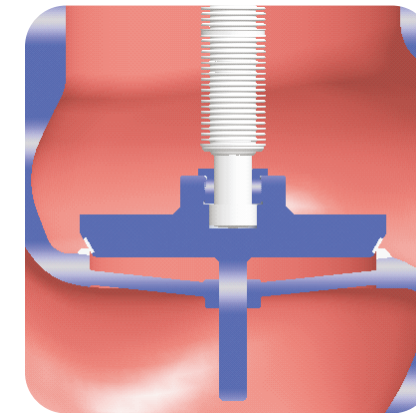

阀瓣型号/Disc type: D8  
中心定位的结构有利于密封和降低噪音  
Central locate structure is good for sealing and lower noise

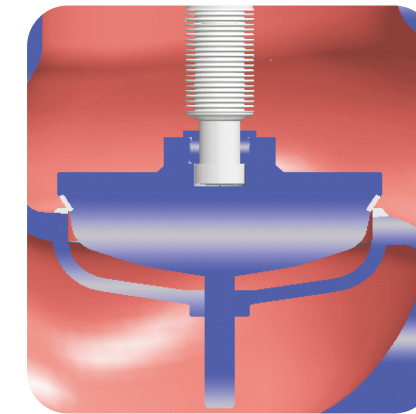

阀瓣型号/Disc type: D9  
中心定位的流线型阀瓣可以防止水锤和降低噪音  
Streamline disc with central locate structure can prevent water hammer and lower noise.

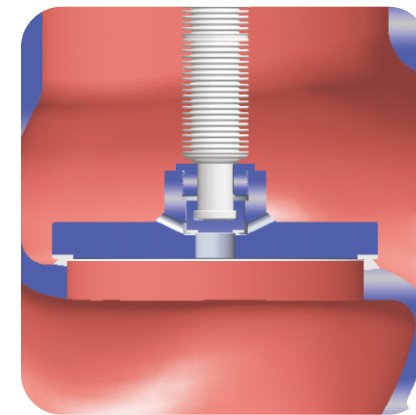

阀瓣型号/Disc type: D10  
双重阀瓣设计，第二个阀瓣能够缓解压力，并且便于开启和关闭  
Double disc design, the second disc can relieve pressure and easy for opening and closing.

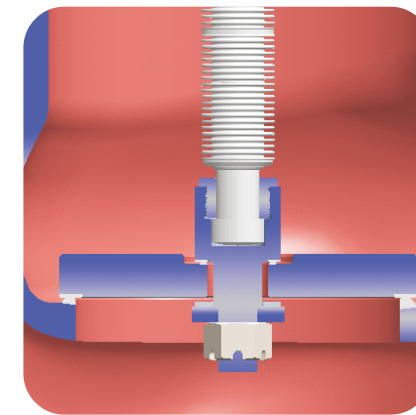

阀瓣型号/Disc type: D11  
平衡型的阀瓣更加容易开启，密封性能更好，通常用于DN200以上的阀门  
Balance type disc is easy for opening, with good sealing, applied while valve size bigger than Dn200

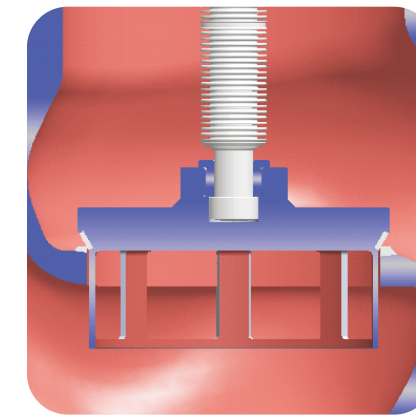

阀瓣型号/Disc type: D12  
窗口形状的调节阀瓣，能精准的控制流量  
Window shape regulating disc, control the flow rate precisely.



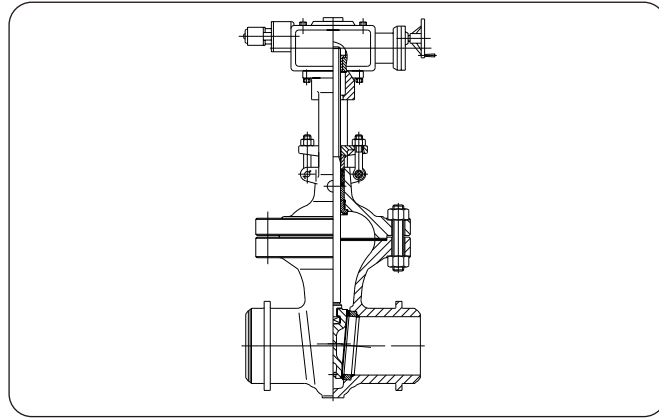

所有闸阀、截止阀均可选配电动和气动  
All gate and globe valves can be equipped with electric or Pneumatic actuator.

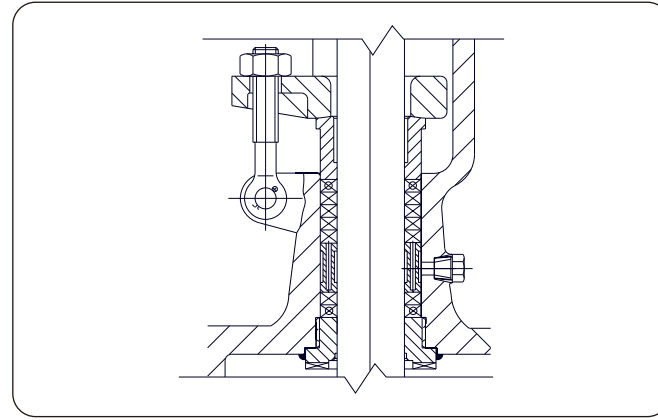

闸阀、截止阀的真空结构  
The lantern on the gate and globe valves

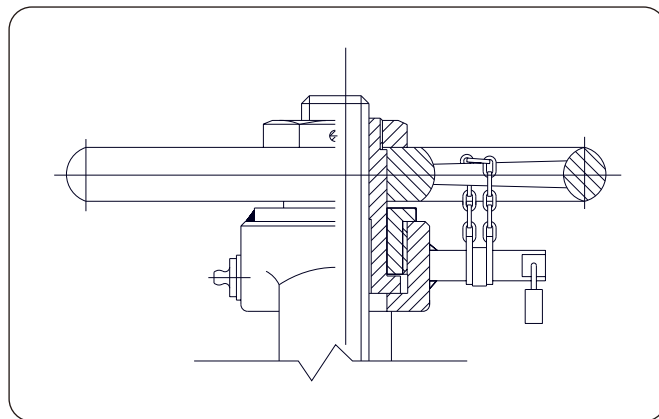

手轮带锁  
Locking device on the handwheel

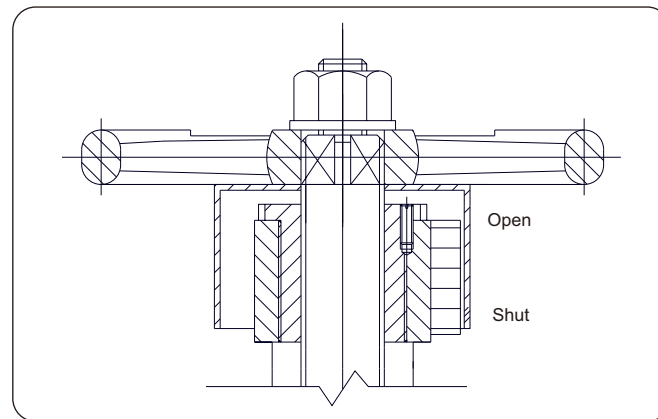

截止阀的位置指示器  
Position indicator on globe valves

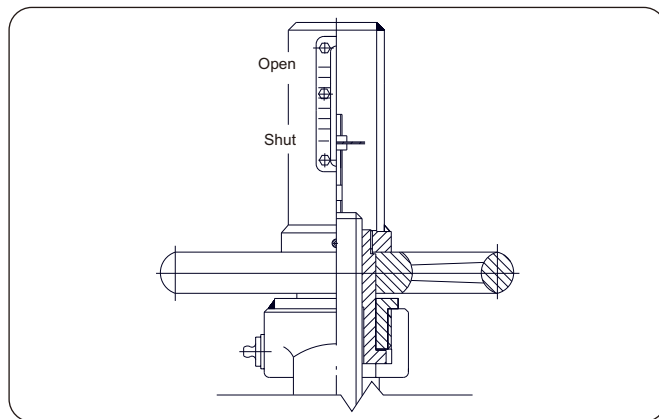

闸阀的位置指示器  
Position indicator on gate valves

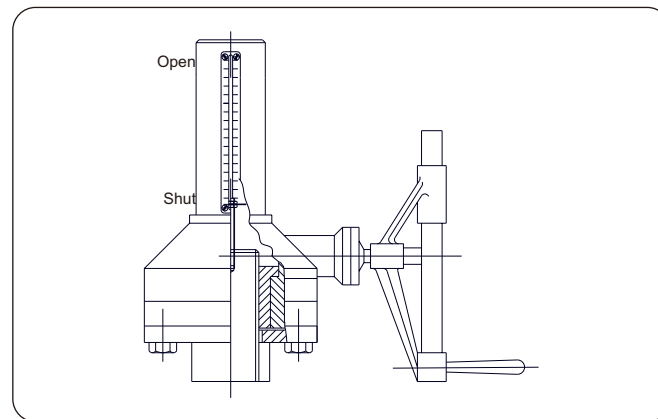

伞齿轮的位置指示器  
Position indicator on gear box

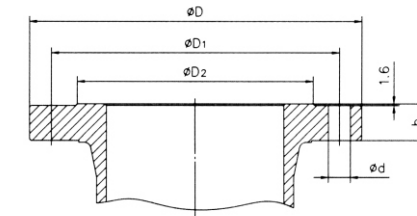

Class150LB & Class 300LB RF 法兰/Flanges

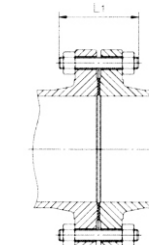

螺柱螺栓长度  
Length of Stud Bolt

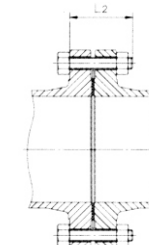

机器螺栓长度  
Length of Machine Bolt

ASME B16.5 RF 钢管法兰 ASME B16.5 RF Steel Pipe Flanges

Class	标称尺寸 Nominal Size		D		D1		D2		b		d		螺栓 Bolt		L1		L2	
	NPS	DN	in	mm	in	mm	in	mm	in	mm	in	mm	in	mm	in	mm	in	mm
150 PN20	1/2	15	3.50	89	2.38	60.5	1.38	35	0.38	10	0.62	16	4	1/2	2.25	57	2.00	51
	3/4	20	3.88	98	2.75	69.9	1.69	43	0.41	10.5	0.62	15	4	1/2	2.50	64	2.00	51
	1	25	4.25	108	3.12	79.5	2.00	51	0.44	11.5	0.62	15	4	1/2	2.50	64	2.25	57
	1-1/4	32	4.62	117	3.50	88.9	2.50	64	0.50	13	0.62	16	4	1/2	2.75	70	2.25	64
	1-1/2	40	5.00	127	3.88	98.6	2.88	73	0.56	14.5	0.62	16	4	1/2	2.75	70	2.50	70
	2	50	6.00	152	4.75	120.7	3.62	92	0.62	16	0.75	19	4	5/8	3.25	83	2.75	76
	2-1/2	65	7.00	178	5.50	139.7	4.12	105	0.69	18	0.75	19	4	5/8	3.50	89	3.00	76
	3	80	7.50	190	6.00	152.4	5.00	127	0.75	19.5	0.75	19	4	5/8	3.50	89	3.00	76
	4	100	9.00	229	7.50	190.5	6.19	157	0.94	24	0.75	19	8	5/8	3.50	89	3.00	76
	5	125	10.00	254	8.50	215.9	7.31	186	0.94	24	0.88	22	8	3/4	3.75	95	3.25	83
	6	150	11.00	279	9.50	241.5	8.50	216	1.00	26	0.88	22	8	3/4	4.00	102	3.25	83
	8	200	13.50	343	11.75	298.5	10.62	270	1.12	29	0.88	22	8	3/4	4.25	108	3.50	89
	10	250	16.00	406	14.25	362.0	12.75	324	1.19	30.5	1.00	25	12	7/8	4.50	114	4.00	102
	12	300	19.00	483	17.00	431.8	15.00	381	1.25	32	1.00	25	12	7/8	4.75	121	4.00	102
14	350	21.00	533	18.75	476.3	16.25	413	1.38	35	1.12	29	12	1	5.25	133	4.50	114	
16	400	23.50	597	21.25	540	18.50	470	1.44	37	1.12	29	16	1	5.25	133	4.50	114	
18	450	25.00	635	22.75	577.9	21.00	533	1.56	40	1.25	32	16	11/8	5.75	146	5.00	127	
20	500	27.50	699	25.00	635.0	23.00	584	1.69	43	1.25	32	20	11/8	6.25	159	5.50	140	
24	600	32.00	813	29.50	749.3	27.25	692	1.88	48	1.38	35	20	11/4	6.75	171	6.00	152	
300 PN50	1/2	15	3.75	95	2.62	67.0	1.38	35	-	-	0.62	16	4	1/2	2.50	64	2.25	57
	3/4	20	4.62	117	3.25	83.0	1.69	43	-	-	0.75	19	4	5/8	3.00	76	2.50	64
	1	25	4.88	124	3.50	89.0	2.00	51	0.69	18	0.75	19	4	5/8	3.00	76	2.50	64
	1-1/4	32	5.25	133	3.88	99.0	2.50	64	0.75	19.5	0.75	19	4	5/8	3.25	83	2.75	70
	1-1/2	40	6.12	155	4.50	114.0	2.88	73	0.81	21	0.88	22	4	3/4	3.50	89	3.00	76
	2	50	6.50	165	5.00	127.0	3.62	92	0.88	22.5	0.75	19	8	5/8	3.50	89	3.00	76
	2-1/2	65	7.50	191	5.88	149.4	4.12	105	1.00	25.5	0.88	22	8	3/4	4.00	102	3.25	83
	3	80	8.25	210	6.62	168.1	5.00	127	1.12	29	0.88	22	8	3/4	4.25	108	3.50	89
	4	100	10.00	254	7.88	200.2	6.19	157	1.25	32	0.88	22	8	3/4	4.50	114	3.75	95
	5	125	11.00	279	9.25	235.0	7.31	186	1.38	35	0.88	22	8	3/4	4.75	121	4.25	108
	6	150	12.50	318	10.62	269.7	8.50	216	1.44	37	0.88	22	12	3/4	4.75	121	4.25	108
	8	200	15.00	381	13.00	330.2	10.62	270	1.62	41.5	1.00	25	12	7/8	5.50	140	4.75	121
	10	250	17.50	445	15.25	387.4	12.75	324	1.88	48	1.12	29	16	1	6.25	159	5.50	140
	12	300	20.50	521	17.75	450.9	15.00	381	2.00	51	1.25	32	16	11/8	6.75	171	5.75	146
14	350	23.00	584	20.25	514.5	16.25	413	2.12	54	1.25	32	20	11/8	7.00	178	6.25	159	
16	400	25.50	648	22.50	571.5	18.50	470	2.25	57.5	1.38	35	20	11/4	7.50	191	6.50	165	
18	450	28.00	711	24.75	628.7	21.00	533	2.38	60.5	1.38	35	24	11/4	7.75	197	6.75	171	
20	500	35.50	775	27.00	685.8	23.00	584	2.50	63.5	1.38	35	24	11/4	8.00	203	7.25	184	
24	600	36.00	914	32.00	812.8	27.25	692	2.75	70	1.62	41	24	11/2	9.00	229	8.00	203	

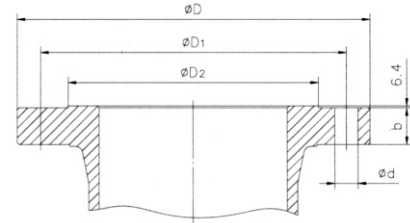

Class 600-2500LB RF 法兰/Flanges

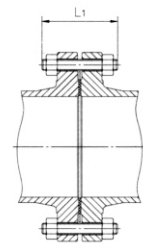

螺柱螺栓长度 Length of Stud Bolt

ASME B16.5 RF 钢管法兰 ASME B16.5 RF Steel Pipe Flanges

Class	标称尺寸 Nominal Size		D		D1		D2		b		d		螺栓 Bolt		L1	
	NPS	DN	in	mm	in	mm	in	mm	in	mm	in	mm	in	mm	in	mm
600 PN110	1/2	15	3.75	95	2.62	66.5	1.38	35	0.56	14	0.62	16	4	1/2	3.00	76
	3/4	20	4.62	117	3.25	82.6	1.69	43	0.62	16	0.75	19	4	5/8	3.50	89
	1	25	4.88	124	3.50	88.9	2.00	51	0.69	18	0.75	19	4	5/8	3.50	89
	1-1/4	32	5.25	133	3.88	98.6	2.50	64	0.81	21	0.75	19	4	5/8	3.75	95
	1-1/2	40	6.12	155	4.50	114.3	2.88	73	0.88	22	0.88	22	4	3/4	4.25	108
	2	50	6.50	165	5.00	127.0	3.62	92	1.00	25	0.75	19	8	5/8	4.25	108
	2-1/2	65	7.50	191	5.88	149.4	4.12	105	1.12	28	0.88	22	8	3/4	4.75	121
	3	80	8.25	210	6.62	168.1	5.00	127	1.25	32	0.88	22	8	3/4	5.00	127
	4	100	10.75	273	8.50	215.9	6.19	157	1.50	38	1.00	25	8	7/8	5.75	146
	5	125	13.00	330	10.50	266.7	7.31	186	1.75	44	1.12	28	8	1	6.50	165
	6	150	14.00	356	11.50	292.1	8.50	216	1.88	48	1.12	29	12	1	6.75	171
	8	200	16.50	419	13.75	349.3	10.62	270	2.19	56	1.25	32	12	1-1/8	7.50	191
	10	250	20.00	508	17.00	431.8	12.75	324	2.50	63.5	1.38	35	16	1-1/4	8.50	216
	12	300	22.00	559	19.25	489.0	15.00	381	2.62	67	1.38	35	20	1-1/4	8.75	222
	14	350	23.75	603	20.75	527.1	16.25	413	2.75	70	1.50	38	20	1-1/4	9.25	235
	16	400	27.00	686	23.75	603.3	18.50	470	3.00	76.5	1.62	41	20	1-1/2	10.00	254
18	450	29.25	743	25.75	654.1	21.00	533	3.25	83	1.75	44	20	1-5/8	10.75	273	
20	500	32.00	813	28.50	723.9	23.00	584	3.50	89	1.75	44	24	1-5/8	11.25	286	
24	600	37.00	940	33.00	838.2	27.25	692	4.00	102	2.00	52	24	1-7/8	13.00	330	
900 PN150	1/2	15	4.75	121	3.25	82.6	1.38	35	0.88	22.5	0.88	22	4	3/4	4.25	108
	3/4	20	5.12	130	3.50	88.9	1.69	43	1.00	25.5	0.88	22	4	3/4	4.50	114
	1	25	5.88	149	4.00	101.6	2.00	51	1.12	29	1.00	25	4	7/8	5.00	127
	1-1/4	32	6.25	159	4.38	111.3	2.50	64	1.12	29	1.00	25	4	7/8	5.00	127
	1-1/2	40	7.00	178	4.88	124.0	2.88	73	1.25	32	1.12	28	4	1	5.50	140
	2	50	8.50	216	6.50	165.1	3.62	92	1.50	38.5	1.00	25	8	7/8	5.75	146
	2-1/2	65	9.62	244	7.50	190.5	4.12	105	1.62	41.5	1.12	28	8	1	6.25	159
	3	80	9.50	241	7.50	190.5	5.00	127	1.50	38.5	1.00	25	8	7/8	5.75	146
	4	100	11.50	292	9.25	235.0	6.19	157	1.75	44.5	1.25	32	8	1-1/8	6.75	171
	5	125	13.75	349	11.00	279.4	7.31	186	2.00	51	1.38	35	8	1-1/4	7.50	191
	6	150	15.00	381	12.50	317.5	8.50	216	2.19	56	1.25	32	12	1-1/8	7.50	191
	8	200	18.50	470	15.50	393.7	10.62	270	2.50	63.5	1.50	39	12	1-3/8	8.75	222
	10	250	21.50	546	18.50	469.9	12.75	324	2.75	70	1.50	39	16	1-3/8	9.25	235
	12	300	24.00	610	21.00	533.4	15.00	381	3.12	79.5	1.50	39	20	1-3/8	10.00	254
	14	350	25.25	641	22.00	558.8	16.25	413	3.38	86	1.62	42	20	1-1/2	10.75	273
	16	400	27.75	705	24.25	616.0	18.50	470	3.50	89	1.75	44	20	1-5/8	11.25	286
18	450	31.00	787	27.00	685.8	21.00	533	4.00	102	2.00	51	20	1-7/8	12.75	324	
20	500	33.75	857	29.50	749.3	23.00	584	4.25	108	2.12	54	20	2	13.75	349	
24	600	41.00	1041	35.50	901.7	27.25	692	5.50	140	2.62	67	20	2-1/2	17.25	438	

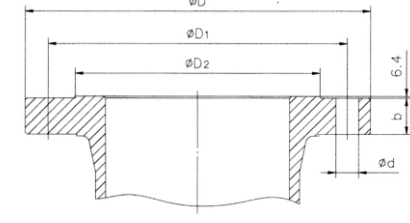

Class 600-2500LB RF 法兰/Flanges

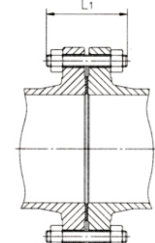

螺柱螺栓长度 Length of Stud Bolt

ASME B16.5 RF 钢管法兰 ASME B16.5 RF Steel Pipe Flanges

Class	标称尺寸 Nominal Size		D		D1		D2		b		d		螺栓 Bolt		L1	
	NPS	DN	in	mm	in	mm	in	mm	in	mm	in	mm	in	mm	in	mm
1500 PN260	1/2	15	4.75	121	3.25	82.6	1.38	35	0.88	22.5	0.88	22	4	3/4	4.25	108
	3/4	20	5.12	130	3.50	88.9	1.69	43	1.00	25.5	0.88	22	4	3/4	4.50	114
	1	25	5.88	149	4.00	101.6	2.00	51	1.12	29	1.00	25	4	7/8	5.00	127
	1-1/4	32	6.25	159	4.38	111.3	2.50	64	1.12	29	1.00	25	4	7/8	5.00	127
	1-1/2	40	7.00	178	4.88	124.0	2.88	73	1.25	32	1.12	28	4	1	5.50	140
	2	50	8.50	216	6.50	165.1	3.62	92	1.50	38.5	1.00	26	8	7/8	5.75	146
	2-1/2	65	9.62	244	7.50	190.5	4.12	105	1.62	41.5	1.12	28	8	1	6.25	159
	3	80	10.50	267	8.00	203.2	5.00	127	1.88	48	1.25	32	8	1-1/8	7.00	178
	4	100	12.25	311	9.50	241.3	6.19	157	2.12	54	1.38	35	8	1-1/4	7.75	197
	5	125	14.75	375	11.50	292.1	7.31	186	2.88	73.5	1.62	41	8	1-1/2	9.75	248
	6	150	15.50	394	12.50	317.5	8.50	216	3.25	83	1.50	38	12	1-3/8	10.25	260
	8	200	19.00	483	15.50	393.7	10.62	270	3.62	92	1.75	44	12	1-5/8	11.50	292
	10	250	23.00	585	19.00	482.6	12.75	324	4.25	108	2.00	51	12	1-7/8	13.25	337
	12	300	26.50	675	22.50	571.5	15.00	381	4.88	124	2.12	54	16	2	14.75	375
	14	350	29.50	750	25.00	635.0	16.25	413	5.25	133.5	2.38	61	16	2-1/4	16.00	406
	16	400	32.50	826	27.75	704.9	18.50	470	5.75	146.5	2.62	67	16	2-1/2	17.50	445
18	450	36.00	914	30.50	774.7	21.00	533	6.38	162	2.88	74	16	2-3/4	19.50	495	
20	500	38.75	985	32.75	831.9	23.00	584	7.00	178	3.12	80	16	3	21.25	540	
24	600	46.00	1168	39.00	990.6	27.25	692	8.00	203.5	3.62	92	16	3-1/2	24.25	616	
2500 PN420	1/2	15	5.25	133	3.50	88.9	1.38	35	1.19	30.5	0.88	22	4	3/4	4.75	121
	3/4	20	5.50	140	3.75	95.3	1.69	43	1.25	32	0.88	22	4	3/4	5.00	127
	1	25	6.25	159	4.25	108.0	2.00	51	1.38	35	1.00	25	4	7/8	5.50	140
	1-1/4	32	7.25	184	5.12	130.0	2.50	64	1.50	38.5	1.12	28	4	1	6.00	152
	1-1/2	40	8.00	203	5.75	146.1	2.88	73	1.75	44.5	1.25	32	4	1-1/8	6.75	171
	2	50	9.25	235	6.75	171.5	3.62	92	2.00	51	1.12	28	8	1	7.00	178
	2-1/2	65	10.50	267	7.75	196.9	4.12	105	2.25	57.5	1.25	32	8	1-1/8	7.75	197
	3	80	12.00	305	9.00	228.6	5.00	127	2.62	67	1.38	35	8	1-1/4	8.75	222
	4	100	14.00	356	10.75	273.1	6.19	157	3.00	76.5	1.62	41	8	1-1/2	10.00	254
	5	125	16.50	419	12.75	323.9	7.31	186	3.62	92.5	1.88	48	8	1-3/4	11.75	298
	6	150	19.00	483	14.50	368.3	8.50	216	4.25	108	2.12	54	8	2	13.50	343
	8	200	21.75	552	17.25	438.2	10.62	270	5.00	127	2.12	54	12	2	15.00	381
10	250	26.50	675	21.25	539.8	12.75	324	6.50	165.5	2.62	67	12	2-1/2	19.25	489	
12	300	30.00	762	24.38	619.3	15.00	381	7.25	184.5	2.88	73	12	2-3/4	21.25	540	



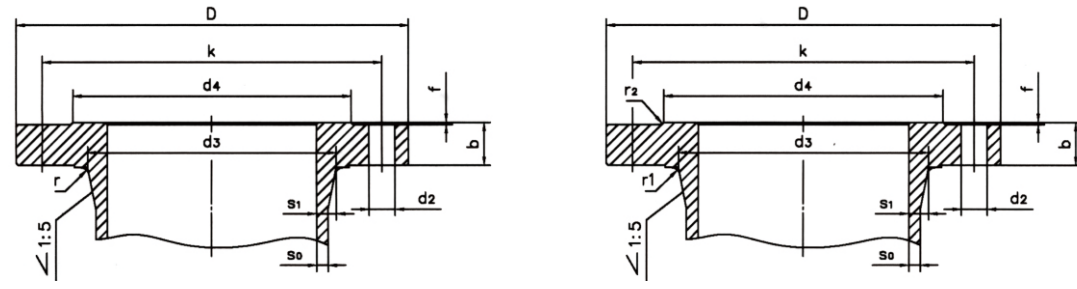

a)1.6-4.0MPa

b)6.4-40.0MPa

PN1.6Mpa钢制管法兰 (BS EN 1092-1:2005) PN1.6MPa Steel pipe flange (BS EN 1092-1:2005)

DN	法兰 Flange			法兰颈 Flange Neck				凸面 Raised Face		螺栓 Bolt		
	D	b	k	So	d <sub>3</sub>	S1(max)	r	d <sub>4</sub>	f	数量 Number	Size	d <sub>2</sub>
10~50	DN≤50, 尺寸符合DN 2545 4.0MPa DN≤50, the Size Conform to DN 2545 4.0MPa											
65	185	18	145	8	93	14	5	122	3	4	M16	18
80	200	20	160	8.5	110	15	5	138	3	8		
100	220	20	180	9.5	130	15	5	158	3			
125	250	22	210	10	159	17	6	188	3			
150	285	22	240	11	184	17	6	212	3		12	M20
(175)	315	24	270	12	211	18	6	242	3			
200	340	24	295	12	236	18	6	268	3			
250	405	26	355	14	290	20	8	320	3			
300	460	28	410	15	342	21	8	378	4	16	M24	26
350	520	30	470	16	396	23	8	438	4			
400	580	32	525	18	448	24	10	490	4			
500	715	36	650	21	554	27	10	610	4			
600	840	40	770	23	660	30	10	725	5	20	M30	33
700	910	42	840	24	760	30	12	795	5			
800	1025	42	950	26	864	32	12	900	5			
900	1125	44	1050	27	966	33	12	1000	5			
1000	1255	46	1170	29	1070	35	12	1115	5	24	M33	36
1200	1485	52	1390	32	1278	39	15	1330	5			
1400	1685	58	1590	34	1488	44	15	1530	5			
1600	1930	64	1820	36	1696	48	18	1750	5			
1800	2130	68	2020	39	1902	51	18	1950	5	28	M36	39
2000	2345	70	2230	41	2106	53	18	2150	5			
2200	2555	74	2440	43	2312	56	18	2360	6			

PN2. 5Mpa钢制管法兰 (BS EN 1092-1:2005) PN2. 5MPa Steel pipe flange (BS EN 1092-1:2005)

DN	法兰 Flange			法兰颈 Flange Neck				凸面 Raised Face		螺栓 Bolt		
	D	b	k	So	d <sub>3</sub>	S1(max)	r	d <sub>4</sub>	f	数量 Number	Size	d <sub>2</sub>
10~150	DN≤150, 尺寸符合DN 2545 4.0MPa DN≤150, the Size Conform to DN 2545 4.0MPa											
175	330	28	280	12	217	21	8	248	3	12	M24	26
200	360	30	310	12	246	23	8	278	3			
250	425	32	370	14	298	24	10	335	3			
300	485	34	430	15	352	26	10	395	4			
350	555	38	490	16	408	29	10	450	4	16	M30	33
400	620	40	550	18	460	30	10	505	4			
500	730	44	660	21	566	33	12	615	4			
600	845	46	770	23	670	35	12	720	5			
700	960	50	875	24	776	38	12	820	5	20	M36	39
800	1085	54	990	26	882	41	15	930	5			
900	1185	58	1090	27	988	44	15	1030	5			
1000	1320	62	1210	29	1094	47	18	1140	5			
1200	1530	70	1420	32	1306	53	18	1350	5	24	M39	42
1400	1755	76	1640	34	1514	57	18	1560	5			
1600	1975	84	1860	37	1726	63	20	1780	5			
1800	2195	90	2070	40	1963	68	20	1985	5			
2000	2425	96	2300	43	2144	72	20	2210	5	28	M52	56

PN4. 0Mpa钢制管法兰 (BS EN 1092-1:2005) PN4. 0MPa Steel pipe flange (BS EN 1092-1:2005)

DN	法兰 Flange			法兰颈 Flange Neck				凸面 Raised Face		螺栓 Bolt		
	D	b	k	So	d <sub>3</sub>	S1(max)	r	d <sub>4</sub>	f	数量 Number	Size	d <sub>2</sub>
10	90	16	60	6	30	10	4	40	2	4	M12	14
15	95	16	65	6	37	11	4	45	2			
20	105	18	75	6.5	44	12	5	58	2			
25	115	18	85	7	53	14	5	68	2			
32	140	18	100	7	60	14	5	78	2	8	M16	18
40	150	18	110	7.5	68	14	5	88	3			
50	165	18	125	8	80	15	5	102	3			
65	185	22	145	8.5	99	17	6	122	3			
80	200	24	160	9	116	18	6	138	3	12	M20	22
100	235	24	190	10	136	18	6	162	3			
125	270	26	220	11	165	20	8	188	3			
150	300	28	250	12	192	21	8	218	3			
(175)	350	32	295	13	223	24	10	260	3	16	M24	26
200	375	34	320	14	252	26	10	285	3			
250	450	38	385	16	308	29	10	345	3			
300	515	42	450	17	364	32	12	410	4			
350	580	46	510	19	420	35	12	465	4	20	M30	33
400	660	50	585	21	476	38	12	535	4			
(450)	685	50	610	21	526	38	12	560	4			
500	755	52	670	21	578	39	15	615	4			
600	890	60	795	24	690	45	15	735	5	24	M36	39
700	995	64	900	27	796	48	18	840	5			
800	1140	72	1030	30	908	54	18	960	5			
900	1250	76	1140	33	1014	57	18	1070	5			
1000	1360	80	1250	36	1120	60	20	1180	5	28	M45	48
1200	1575	88	1460	42	1332	66	20	1380	5			
1400	1795	98	1680	47	1548	74	20	1600	5			
1600	2025	108	1900	54	1762	81	20	1815	5			

**PN6. 3Mpa钢制管法兰 (BS EN 1092-1:2005) PN6. 3MPa Steel pipe flange (BS EN 1092-1:2005)**

DN	法兰 Flange			法兰颈 Flange Neck			凸面 Raised Face			螺栓 Bolt			
	D	b	k	So	d <sub>3</sub>	S1(max)	r	d <sub>4</sub>	f	r <sub>2</sub>	数量 Number	Size	d <sub>2</sub>
10~25	DN10-DN25尺寸符合DIN2548 16.0MPa DN10-DN25 The Size Conform to DIN2548 16.0MPa												
32	DN32尺寸符合DIN2547 10.0MPa DN32 The Size Conform to DIN2547 10.0MPa												
40	DN40尺寸符合DIN2548 16.0MPa DN40 The Size Conform to DIN2548 16.0MPa												
50	180	26	135	10	90	20	5	102	3	1.5	4	M20	22
65	205	26	160	10	105	20	5	122	3	1.5			
80	215	28	170	11	122	21	5	138	3	1.5			
100	250	30	200	12	146	23	5	162	3	1.5			
125	295	34	240	13	177	26	6	188	3	1.5	8	M27	30
150	345	36	280	14	204	27	6	218	3	1.5			
(175)	375	40	310	15	235	30	8	260	3	1.5			
200	415	42	345	16	264	32	8	285	3	1.5			
250	470	46	400	19	320	35	8	345	3	1.5	12	M33	36
300	530	52	460	21	378	39	10	410	4	2			
350	600	56	525	23	434	42	10	465	4	2			
400	670	60	585	26	490	45	12	535	4	2			
500	800	68	705	31	602	51	12	615	4	2	16	M39	42
600	930	76	820	35	714	57	15	735	4	2			
700	1045	84	935	40	826	63	15	840	4	2			
800	1165	92	1050	45	938	69	18	960	4	2			
900	1285	98	1170	50	1046	74	18	1070	4	2	24	M56	62
1000	1415	108	1290	55	1162	81	18	1180	4	2			
1200	1665	126	1530	64	1390	95	18	1380	4	2			
											32	M72X6	78

**PN10. 0Mpa钢制管法兰 (BS EN 1092-1:2005) PN10. 0MPa Steel pipe flange (BS EN 1092-1:2005)**

DN	法兰 Flange			法兰颈 Flange Neck			凸面 Raised Face			螺栓 Bolt			
	D	b	k	So	d <sub>3</sub>	S1(max)	r	d <sub>4</sub>	f	r <sub>2</sub>	数量 Number	Size	d <sub>2</sub>
10~25	DN10-DN25尺寸符合DIN2548 16.0MPa DN10-DN25 The Size Conform to DIN2548 16.0MPa												
32	155	24	110	12	63	15	6	75	3	1.5	4	M20	22
40~100	DN10-DN100尺寸符合DIN2548 16.0MPa DN10-DN100 The Size Conform to DIN2548 16.0MPa												
125	315	40	250	16	185	30	6	188	3	1.5	8	M30	33
150	355	44	290	18	216	33	6	218	3	1.5			
(175)	385	48	320	20	247	36	8	260	3	1.5			
200	430	52	360	21	278	39	8	285	3	1.5			
250	505	60	430	25	340	45	8	345	3	1.5	12	M36	39
300	585	68	500	29	402	51	10	410	4	2			
350	655	74	560	32	460	55	10	465	4	2			
400	715	78	620	36	518	59	12	535	4	2			
500	870	94	760	44	630	70	15	615	4	2	16	M45	48
600	990	104	875	51	740	78	15	735	4	2			
700	1145	120	1020	59	860	90	18	840	4	2			

**PN16. 0Mpa钢制管法兰 (BS EN 1092-1:2005) PN16. 0MPa Steel pipe flange (BS EN 1092-1:2005)**

DN	法兰 Flange			法兰颈 Flange Neck			凸面 Raised Face			螺栓 Bolt				
	d <sub>b</sub>	D	b	k	So	d <sub>3</sub>	S <sub>1</sub>	r	d <sub>4</sub>	f	r <sub>2</sub>	数量 Number	Size	d <sub>2</sub>
10	10	100	20	70	10	40	15	4	40	2	1	4	M12	14
15	15	105	20	75	10	45	15	4	45	2	1			
25	25	140	24	100	10	61	18	4	68	2	1			
40	40	170	28	125	10	82	21	4	88	3	1.5			
50	50	195	30	145	10	96	23	4	102	3	1.5	8	M24	26
65	70	220	34	170	11	118	24	5	122	3	1.5			
80	80	230	36	180	12	128	24	5	138	3	1.5			
100	97	265	40	210	14	150	25	5	162	3	1.5			
125	130	315	44	250	16	184	29.5	6	188	3	1.5	12	M30	33
150	153	355	50	290	18	224	37	6	218	3	1.5			
(175)	171	390	54	320	19	250	37.5	8	260	3	1.5			
200	194	430	60	360	21	288	44	8	285	3	1.5			
250	239	515	68	430	31	346	48	8	345	3	1.5	16	M39	42
300	286	585	78	500	36	414	57	10	410	4	2			

**压力试验和规范 Pressure Test And Specification**

DN	壳体试验 Shell Test		水封试验 Water Seal Test		气封试验 Air Seal Test	
	MPa	Lbf/in <sup>2</sup>	MPa	Lbf/in <sup>2</sup>	MPa	Lbf/in <sup>2</sup>
150	3.1	450	2.2	315	0.5~0.7	60-100
300	7.8	1125	5.6	815		
600	15.3	2225	11.2	1630		
900	23.1	3350	16.8	244Q		
1500	38.4	5575	28.1	4080		
2500	64.6	9367	47.4	6873		
1.6	2.4		1.76		0.5~0.7	
2.5	3.75		2.75			
4.0	6.0		4.4			
6.3	9.6		7.04			
10.0	15.0		11.0			
16.0	240		17.6			